



VOL. 3, NO. 1, JANUARY - MARCH 1976

SERVICE NEWS

A SERVICE PUBLICATION OF LOCKHEED-GEORGIA COMPANY, A DIVISION OF LOCKHEED AIRCRAFT CORPORATION



SERVICE NEWS

A SERVICE PUBLICATION OF
LOCKHEED-GEORGIA COMPANY
 A DIVISION OF
LOCKHEED AIRCRAFT CORPORATION

Editor

Jay V. Roy

Associate Editors

James W. Buttram

James A. Loftin

Art Direction & Production

Anne G. Anderson

SERVICE NEWS



Cover: Royal Australian Air Force C-130 Hercules over Sydney Harbor.

Published by Lockheed-Georgia Company, a Division of Lockheed Aircraft Corporation. Information contained in this issue is considered by Lockheed-Georgia Company to be accurate and authoritative; it should not be assumed, however, that this material has received approval from any governmental agency or military service unless it is specifically noted. This publication is for planning and information purposes only, and it is not to be construed as authority for making changes on aircraft or equipment, or as superseding any established operational or maintenance procedures or policies. The following marks are registered and owned by Lockheed Aircraft Corporation: "LOCKHEED", "Lockheed", "Hercules", and "JetStar". Written permission must be obtained from Lockheed-Georgia Company before republishing any material in this periodical. Address all communications to Editor, Service News, Department 64-22 Zone 278, Lockheed-Georgia Company, Marietta, Georgia 30063. Copyright 1976 Lockheed Aircraft Corporation.

Vol. 3, No. 1, January – March 1976

CONTENTS

- 3** **Preformed Packings**
- 5** CHART 1 A Service Specifications for Rubber Packings and Seals
- 6** CHART 1 B Service Specifications of Teflon Backup Rings
- 6** CHART 2 Lockheed Specifications – Rubber O-Rings
- 7** CHART 3A Rubber O-Rings – Cross Reference Part Numbers and Dimensions
- 11** CHART 3B Teflon Backup Rings – Cross Reference Part Numbers and Dimensions
- 13** CHART 3C Tube Fitting to Boss – Cross Reference Part Numbers, Tube Sizes, and Dimensions

- 14** **Seals by Greene, Tweed & Company**
- 15** G-T Ring Chart

- 15** **Servicing Hercules Hydraulic Filters**
- 16** Seals for Servicing Hercules Hydraulic Filters

- 17** **Care and Handling of Preformed Packings**

- 18** **Nose Wheel Shimmy**
 And What to do About It

- 20** **Index 1974 Through 1975**

*j

PRODUCT SUPPORT

DIRECTOR

T.J. CLELAND

CUSTOMER SERVICE DIVISION

MANAGER

D.L. BRAUND

FIELD SERVICE & INVENTORY MGMT

A.H. McCRUM

CUSTOMER TRAINING

A.R. LOVE

JETSTAR SUPPORT

H.L. BURNETTE

SPARES STORES & SHIPPING

J.K. PIERCE

CUSTOMER SUPPLY DIVISION

MANAGER

M.M. HODNETT

SUPPLY PROCUREMENT

R.C. WEIHE

SUPPLY SYSTEMS & INVENTORY CONTROL

C.K. ALLEN

SUPPLY SALES & CONTRACTS

H.T. NISSLEY, JR.

SUPPLY TECHNICAL SUPPORT

J.L. THURMOND



preformed packings

One of the most confusing and aggravating jobs faced by most mechanics is the finding, identifying, removing and replacing preformed packings, most often referred to as simply “O-rings”. This issue of the Service News is for those mechanics – to assist in cross-referencing part numbers, in determining dimensions, and in proper care and handling from storage to installation of preformed packings. We have also included some special listings for Hercules components to save you time.

Preformed Packings

Preformed packings such as O-rings were originally specified under AN (Air Force-Navy) specifications. As advances in aircraft design raised system operating temperatures and pressures, new materials for these packings were developed. These superior materials were adopted under MS (Military Standard) part numbers,



replacing AN part numbers. As new fluids were developed and system requirements changed, O-ring manufacturers developed new material specifications, often under their own part numbers. Cross-referencing of part numbers became a problem.

AN and MS Standards

The need for specific materials for certain applications has been more critical for military aerospace equipment; thus, military drawings and specifications have been accepted as standard by diversified industries as well as aerospace industries.

The major manufacturers of preformed packings publish catalogues that list Air Force-Navy (AN) and Military Standard (MS) part numbers along with their own part numbers for the seals and packings meeting standard specifications. The military specification part numbers may be used to cross-reference one supplier's numbers to those of another source. Each manufacturer's or supplier's in-house numbering systems are unique, but as a rule they relate to standard designations established by military and public agencies.

Definitions

Before we talk about a chart of seals and components, let's define what we are talking about.

- A SEAL is a device meant to retain fluid (which includes air) within a component. A seal may consist of two or more parts, such as a packing in a gland (groove) with backup rings.
- 1 A GASKET is a type of seal formed by crushing the packing material into the gland or open space such that the cavity is normally filled with the packing material.
- A PACKING is the component that, due to its plastic or elastic properties, does the sealing. The most common example is the O-ring.
- The GLAND is the cavity or inclusion that the packing (seal) fits in. It surrounds and supports the packing, controlling the squeeze.
- The SQUEEZE is the amount of distortion of the packing as it forms the seal in the gland.
- BACKUP RINGS are used to prevent pressure and friction from squeezing the O-ring packing through the clearance gap of a seal.

Substitution of Materials

In many packing applications one material can be substituted for another but the reverse substitution may not be recommended. As a general rule the newer materials are compatible with more different fluids than the older materials, and they can function over a wider range of temperatures. For example, MS28775-006 can function in temperatures from -65°F to +275°F, and it

supersedes three other specification/part numbers for hydraulic applications.

Part Numbers

The first attempt at standardizing part numbers for packings was the Air Force-Navy (AN) series of numbers. For example, AN6227B-1 is an O-ring for use in hydraulic systems. The dimensions of the O-ring are 1/8-inch ID (inside diameter) and 1/16 -inch W (width). AN numbers gave way to Military Standard (MS) numbers and dash numbers went from single digit to the present day three digit dash numbers. For example, MS28775-006 superseded AN6227B-1. A chart is necessary to cross-reference the different specification numbers. The Society of Automotive Engineers, Inc. published ARP 568 to standardize the dash numbering of O-rings. This publication has been superseded and cancelled by AS 568.

AS 568 establishes a standardized dash numbering system for O-rings. Each dash number is a three digit number and will be used as a part of the military or manufacturer's specification number to identify one nominal size O-ring. For example, no matter who manufactures the O-ring or what specification number is used, -001 is used to identify an O-ring with specific dimensions. AS 568 gives O-ring dimensions in decimal fractions of inches and millimeters. It is published by the Society of Automotive Engineers, Inc., 2 Pennsylvania Plaza, New York, N.Y. 10001.

Cross-Reference Chart

Our chart cross-references AN, MS, and some LS part numbers. The LS numbers are Lockheed Standard numbers developed for use in the design of the C-130 Hercules, C-141 StarLifter, C-140 JetStar, and/or the C-5A Galaxy.

Heading each of the part number columns in the chart is the first section of the part number for that series of packings. This basic number denotes the service and system specification for the material of the packing. Each dash number appearing below each series number identifies a standard size packing.

Chart IA gives the service specifications for rubber packings and seals. Chart IB gives the service specifications for Teflon backup rings. Lockheed specifications for rubber O-rings are found in Chart 2, while Charts 3A and B are for cross-referencing rubber packings and Teflon backup rings by part number and dimensions. Chart 3C is a cross-reference by part number and tube size for packings and backup rings.

You will find some new basic part numbers in our service applications Charts 1A and 1B that are not included on our part number Chart 3A and 3B. These new packings conform to size and identification standards currently in use.

Chart 1A | SERVICE SPECIFICATIONS FOR RUBBER PACKINGS AND SEALS

BASIC PART NUMBER AND SPECIFICATION	PART NAME AND MATERIAL	SUPERSEDING PART NUMBER	SERVICE AND TEMPERATURE
AN6227B MI L-P-551 6	Packing, O-ring (Groove Seal) Buna N	MS28775	MIL-t-l-5606 Hyd Fluid -65°F to +160°F
AN62306 MI L-P-561 6	Gasket, O-ring (Groove Seal) Buna N	MS28778	MI L-H-5606 Hyd Fluid -65°F to +160°F
AN6290 MIL-G-5510	Gasket (Boss Seal) Buna N	MS28778	MIL-H-5606 Hyd Fluid -65°F to +160°F
AN 123983 AMS7270	Packing, Preformed (Groove Seal) Buna N	None	JP3,4 & 6 Fuel -65°F to +160°F
LS4629 MI L-P-25732	Gasket, O-ring (Groove Seal) Buna N	None	MI L-H-5606 Hyd Fluid -65°F to +275°F
LS4634 None	Gasket (Boss Seal) Buna N	3-()N169-80	MIL-H-5606 Hyd Fluid -65°F to +275°F
LS504 1 Spec. 23-926	Packing, O-ring (Some Groove & some Boss Seals) Buna N	None	MIL-L-7808 Eng Oil -65' F to +300° F
MS9020 AMS727 1	Packing, Preformed (Boss Seal) Buna N	None	JP 3,4 & 5 Fuels -65°F to +160°F
MS902 1 AMS7271	Packing, Preformed (Groove Seal) Buna N	None	JP 3, 4 & 5 Fuels -65°F to +160°F
MS9068 A M33304	Packing, Preformed (Groove Seal) Silicone	None	Breathing Oxygen -65°F to +450 F
MS9241 SMS7272	Packing, Preformed (Groove Seal) Buna N	None	MIL-L-7808 Eng Oil -40°F to +325°F
MS28775 MI L-P-25732	Packing, Preformed (Groove Seal) Buna N	None	MI L-H-6606 Hyd Fluid -65°F to +275°F
MS28778 MIL-G-5510	Packing, Preformed (Boss Seal) Buna N	None	MIL-H-5606 Hyd Fluid -65°F to +160°F
MS28784 MI L-P-18017	Packing (Groove Seal) Buna N	MS28776	MIL-H-5606 Hyd Fluid -65°F to +275°F
MS2951 2 MI L-P-531 5	Packing, Preformed (Boss Seal) Buna N	None	JP Fuel -65°F to +160°F
MS2961 3 M 11-P-5315	Pecking, Preformed (Groove Seal) Buna N	None	JP Fuel -65°F to +160°F
MS29561 MIL-R-7362	Packing, Preformed (Groove Seal) Buna N	None	MIL-L-7808 Eng Oil -65°F to +275°F
NAS1593 MI L-R-25897	Packing, Preformed (Groove Seal) Viton A	M83248/1	MI L-H-8606 Hyd Fluid JP3,4 & 6 Fuel MILL-7808 Eng Oil -65°F to +375F
NAS 1594 MI L-R-25897	Packing, Preformed (Groove Seal) Viton A	M83248/1	↓
NAS 1595 MI L-R-25897	Pecking, Preformed (Boss Seal) Viton A	M83248/2	
NAS 1596 MI L-R-25897	Packing, Preformed (Boss Seal) Viton A	M83248/2	
M83248/1 MI L-R-83248	Packing, O-ring (Groove Seal) Viton A	None	
M83248/2 MI L-R 83248	Gasket (Boss Seal) Viton A	None	

NOTE

1. See MIL-G-5514 for groove dimensions
2. See AND10080 end MS33649 for Boss dimensions



Chart 1B		SERVICE SPECIFICATIONS FOR TEFLON BACKUP RINGS		
BASIC PART NUMBER AND SPECIFICATION		PART NAME AND MATERIAL	SUPERSEDING PART NUMBER	SERVICE AND TEMPERATURE
LS4564 AMS3651		Ring, Backup (Groove Seal) Teflon (Single Turn-Cut)	LS4565	Teflon backup rings can be used in most all fluids including
LS4565 MIL-R-8791		Ring, Backup (Groove Seal) Teflon (Single Turn-Cut)	None	MIL-H-5606 Hyd Fluid MIL-L-7808 Eng Oil JP3, 4 & 5 Fuel, Air and Oxygen
LS4764 AMS3651		Ring, Backup (Boss Seal) Teflon (Single Turn-Cut)	MS9058	
MS28782 MIL-R-8791		Retainer, Backup (Groove Seal) Teflon (Two Spiral Turns)	None	
MS28783 MIL-R-8791		Ring, Backup (Groove Seal) Teflon (Two Spiral Turns)	None	
MS9058 AMS3651		Ring, Backup (Boss Seal) Teflon (Single Turn-Cut)	None	
MS20774 MIL-R-8791		Retainer, Backup (Groove Seal) Teflon (Single Turn-Cut)	None	
AN6246 None		Ring, Backup (Groove Seal) Leather (Single Turn-Not Cut)	LS4565	
MS28773 MIL-R-8791		Retainer, Backup (Boss Seal) Teflon (Single Turn-Cut)	None	
MS27595 MIL-R-8791		Retainer, Backup (Groove Seal) Teflon (Single Turn-Not Cut)	None	

6

Chart 2		LOCKHEED SPECIFICATIONS - RUBBER O-RINGS			
APPLICATION IN TEMPERATURES		-65°F +275°F		Dynamic or Static	
LS4629		NOMINAL DIMENSIONS		ID	
		W		DIMENSIONS CONFORM TO	
-26	4.733	0.139			
-30	5.234				
-38	6.500				
-40	6.984				
-46	8.484				
-50	9.484				
SYNTHETIC OIL RESISTANT		Spec 23-926 Share 65			
LS5041	ID	W	DIMENSIONS CONFORM TO		
-1	0.737	0.103			
-2	2.112	0.103	MS29513-138		
-3	2.425	0.103	MS29513-143		
-4	0.351	0.072	MS29512-4		
-5	0.468	0.078	MS29512-6		
-6	0.924	0.116	MS29512-12		
-7	1.171	0.116	MS29512-16		
-8	1.720	0.118	MS29512-24		
-9	1.609	0.139	MS29513-223		
-10	2.231	0.139	MS29513-228		
-11	5.359	0.139	MS29513-253		
-12	1.475	0.210	MS29533-325		
-13	1.475	0.116	MS29512-20		
LS5041	ID	W	DIMENSIONS CONFORM TO		
-14	6.725	0.275	MS28775-440		
-15	0.644	0.087	AN6290-8		
-17	0.301	0.064	MS29512-3		
-18	1.975	0.210	MS29513-329		
-19	2.475	0.210	MS29513-333		
-20	4.234	0.139	MS29513-244		
-21	7.234	0.139	MS29513-263		
-22	12.109	0.139			
-23	8.975	0.275	MS28775-447		
-24	4.609	0.139	MS29513-247		
-25	6.984	0.139	MS29513-262		
-26	2.609	0.139	MS29513-231		
-27	2.734	0.139	MS29513-232		
-28	0.549	0.103	MS28775-113		
-29	0.203	0.070	MS28775-009		
-30	1.112	0.103	MS29513-122		
-31	.176	0.070	MS29513-8		
-32	0.426	0.070	MS29513-13		
-33	2.484	0.139	MS28775-230		
-34	1.171	0.139	MS29513-217		
-35	1.234	0.139	MS29513-218		
-36	0.239	0.070	MS28775-010		
-37	0.487	0.103	MS28775-112		
-38	2.109	0.139	MS28775-227		
-39	1.549	0.103	MS29513-129		
-40	0.755	0.097	MS28778-10		
-41	0.674	0.103	MS28775-115		
-42	1.046	0.139	MS28775-215		

1B
2

Chart 3A

RUBBER O-RINGS CROSS REFERENCE PART NUMBERS AND DIMENSIONS



AS 568 UNIFORM DASH NO.	NOMINAL DIMENSIONS ID W		AN62279 AN6230B	628775	MS29561	AN123XXX	AN12XXX	MS902 1	MS29513	MS9068	NAS1593 NAS 1594
001	.029	.040		-001							
002	.042	.050		-002							
003	.056	.060		-003							
004	.070			-004	-004			-004	-004	-004	-004
005	.101			-005	-005			-005	-005	-005	-005
006	.114		AN6227B-1	-006	-006	AN123856	AN123956	-006	-006	-006	-006
001	.145		-2	-001	-007	AN123651	AN123951	-001	-007	-007	-001
008	.176		-3	-008	-008	AN123858	AN123958	-008	-008	-008	-008
009	.208		-4	-009	-009	AN123859	AN123959	-009	-009	-009	-009
010	.239		-5	-010	-010	AN123860	AN123960	-010	-010	-010	-010
011	.301		-6	-011	-011	AN123861	Ah'123961	-011	-011	-011	-011
012	.364		AN6227B-7	-012	-012	AN123862	AN123962	-012	-012	-012	-012
013	.420			-013	-013			-013	-013	-013	-013
014	.489			-014	-014			-014	-014	-014	-014
015	.551			-015	-015			-015	-015	-015	-015
016	.614			-016	-016			-016	-016	-016	-016
017	.676			-011	-017			-017	-017	-011	-017
018	.739			-018	-018			-018	-018	-018	-018
019	.801			-019	-019			-019	-019	-019	-019
020	.864			-020	-020			-020	-020	-020	-020
021	.926			-021	-021			-021	-021	-021	-021
022	.989			-022	-022			-022	-022	-022	-022
023	.051			-023	-023			-023	-023	-023	-023
024	.114			-024	-024			-024	-024	-024	-024
025	.176			-025	-025			-025	-025	-025	-025
026	.239			-026	-026			-026	-026	-026	-026
021	.301			-027	-027			-027	-027	-027	-027
028	.364			-028	-028			-028	-028	-028	-028
029	1.489							-029		-029	
030	1.614							-030		-030	-030
031	1.139							-031		-031	-031
032	1.864							-032		-032	-032
033	L.989							-033		-033	-033
034	1.114							-034		-034	-034
035	2.239							-035		-035	-035
036	2.364							-036		-036	-036
031	2.489							-031		-031	-031
038	3.614							-038		-038	-038
039	2.739							-039		-039	-039
040	2.864							-040		-040	-040
041	1.989							-041		-041	-041
042	1.239							-042		-042	-042
043	1.489							-043		-043	-043
044	3.739							-044		-044	-044
045	3.989							-045		-045	-045
046	1.239										-046
047	1.489										-047
048	1.139										-048
049	1.989										-049
050	5.239	.070									-050
110	.362	.103	AN6227B-8	-110	-110	AN123863	AN123963	-110	-110	-110	-110
111	.424		-9	-111	-111	AN123864	AN123964	-111	-111	-111	-111
112	.487		-10	-112	-112	AN123865	AN123965	-112	-112	-112	-112
113	.549		-11	-113	-113	AN123866	AN123966	-113	-113	-113	-113
114	.612		-12	-114	-114	AN123867	AN123967	-114	-114	-114	-114
115	.674		-13	-115	-115	AN123868	AN123968	-115	-115	-115	-115
116	.737		AN6227B-14	-116	-116	AN123869	AN123969	-116	-116	-116	-116
117	.799			-117	-117			-117	-117	-111	-117
118	.862			-118	-118			-118	-118	-118	-118
119	.924			-119	-119			-119	-119	-119	-119
120	.987			-120	-120			-120	-120	-120	-120
121	1.049			-121	-121			-121	-121	-121	-121
122	1.112			-122	-122			-122	-122	-122	-122
123	1.114	.103		-1 2 3	-123			-123	-1 2 3	-1 2 3	-1 2 3





AS.669 UNIFORM DASH NO	NOMINAL DIMENSIONS ID W	AN62278 AN6230B	628775	MS29561	AN123XXX	AN12XXXX	MS9021	MS29513	MS9068	AS1593 AS1594
124	1.237		-124	-124			-124	-124	-124	-124
125	1.299		-125	-125			-125	-125	-125	-125
126	1.362		-126	-126			-126	-126	-126	-126
127	1.424		-127	-127			-127	-127	-127	-127
128	1.481		-128	-128			-128	-128	-128	-128
129	1.549		-129	-129			-129	-129	-129	-129
130	1.612		-130	-130			-130	-130	-130	-130
131	1.674		-131	-131			-131	-131	-131	-131
132	1.737		-132	-132			-132	-132	-132	-132
133	1.799		-133	-133			-133	-133	-133	-133
134	1.862		-134	-134			-134	-134	-134	-134
135	1.925		-135	-135			-135	-135	-135	-135
136	1.987		-136	-136			-136	-136	-136	-136
137	2.050		-137	-137			-137	-137	-137	-137
138	2.112		-138	-138			-138	-138	-138	-138
139	2.175		-139	-139			-139	-139	-139	-139
140	2.237		-140	-140			-140	-140	-140	-140
141	2.300		-141	-141			-141	-141	-141	-141
142	2.362		-142	-142			-142	-142	-142	-142
143	2.425		-143	-143			-143	-143	-143	-143
144	2.487		-144	-144			-144	-144	-144	-144
145	2.550		-145	-145			-145	-145	-145	-145
146	2.612		-146	-146			-146	-146	-146	-146
147	2.675		-147	-147			-147	-147	-147	-147
148	2.737		-148	-148			-148	-148	-148	-148
149	2.800		-149	-149			-149	-149	-149	-149
150	2.862						-150		-150	-150
151	2.987						-151		-151	-151
152	3.237						-152		-152	-152
153	3.487						-153		-153	-153
154	3.737						-154		-154	-154
155	3.987						-155		-155	-155
156	4.237						-156		-156	-156
157	4.487						-157		-157	-157
158	4.737						-158		-158	-158
159	4.987						-159		-159	-159
160	5.237						-160		-160	-160
161	5.487						-161		-161	-161
162	5.737						-162		-162	-162
163	5.987						-163		-163	-163
164	6.237									-164
165	6.487									-165
166	6.737									-166
167	6.987									-167
168	7.237									-168
169	7.487									-169
170	7.737									-170
171	1.987									-171
172	8.237									-172
173	8.487									-173
174	8.737									-174
175	8.987									-175
176	9.237									-176
177	9.487									-177
178	9.737									-178
210	.734		-210	-210	AN123870	AN123970	-210	-210	-210	-210
211	.796		-211	-211	AN123871	AN123971	-211	-211	-211	-211
212	.859		-212	-212	AN123872	AN123972	-212	-212	-212	-212
213	.921		-213	-213	AN123873	AN123973	-213	-213	-213	-213
214	.984		-214	-214	Ah.123874	AN123974	-214	-214	-214	-214
215	1.046		-215	-215	AN123875	AN123975	-215	-215	-215	-215
216	1.109		-216	-216	AN123876	AN123976	-216	-216	-216	-216
217	1.171		-217	-217	AN123877	AN123977	-217	-217	-217	-217
218	1.234		-218	-218	AN123878	AN123978	-218	-218	-218	-218

8

RUBBER O-RINGS CROSS REFERENCE PART NUMBERS AND DIMENSIONS



AS 568 UNIFORM DASH NO.	NOMINAL DIMENSIONS ID W	AN6227B AN6230B	MS28775	MS2956 1	AN123XXX	AN12XXX	MS9021	MS29513	MS9068	NAS1593 NAS1594
219	1.296 .139	-24	-219	-219	AN123879	AN123979	-219	-219	-219	-219
220	1.359	-25	-220	-220	AN123880	AN123980	-220	-220	-220	-220
221	1.421	-26	-221	-221	AN123881	AN123981	-221	-221	-221	-221
222	1.484	AN6227B-27	-222	-222	AN123882	AN123982	-222	-222	-222	-222
223	1.609	AN6230B-1	-223	-223	AN123883	AN123983	-223	-223	-223	-223
224	1.734	-2	-224	-224	AN123884	AN123984	-224	-224	-224	-224
225	1.859	-3	-225	-225	AN123885	AN123885	-228	-225	-225	-285
228	1.984	-4	-226	-226	AN123886	AN123986	-226	-226	-226	-226
227	2.109	-5	-227	-227	AN123887	AN123987	-227	-227	-227	-227
228	2.234	-6	-228	-228	AN123888	AN123988	-228	-228	-228	-228
229	2.359	-7	-229	-229	AN123889	AN123989	-229	-229	-229	-229
230	2.484	-8	-230	-230	AN123890	AN123990	-230	-230	-230	-230
231	2.609	-9	-231	-231	AN123891	AN123991	-231	-231	-231	-231
232	2.734	-10	-232	-232	AN123892	AN123992	-232	-232	-232	-232
233	2.859	-11	-233	-233	AN123893	AN123993	-233	-233	-233	-233
234	2.984	-12	-234	-234	AN123894	AN123994	-234	-234	-234	-234
235	3.109	-13	-235	-235	AN123895	AN123995	-235	-235	-235	-235
236	3.234	-14	-236	-236	AN123896	AN123996	-236	-236	-236	-236
237	3.359	-15	-237	-237	AN123897	AN123997	-237	-237	-237	-237
238	3.484	-16	-238	-238	AN123898	AN123998	-238	-238	-238	-238
239	3.609	-17	-239	-239	AN123899	AN123999	-239	-239	-239	-239
240	3.734	-18	-240	-240	AN123900	AN124000	-240	-240	-240	-240
241	3.859	-19	-241	-241	AN123901	AN124001	-242	-242	-241	-241
242	3.984	-20	-242	-242	AN123902	AN124002	-242	-242	-242	-242
243	4.109	-21	-243	-243	AN123903	AN124003	-243	-243	-243	-243
244	4.234	-22	-244	-244	AN123904	AN124004	-244	-244	-244	-244
245	4.359	-23	-245	-245	AN123905	AN124005	-245	-245	-245	-245
246	4.484	-24	-246	-246	AN123906	AN124006	-246	-246	-246	-246
247	4.609	-25	-247	-347	AN123907	AN124007	-247	-247	-247	-247
248	4.734	-26	-248	-248	AN123908	AN124008	-248	-248	-248	-248
249	4.859	-27	-249	-249	AN123909	AN124009	-249	-249	-249	-249
250	4.984	-28	-250	-250	AN123910	AN124010	-250	-250	-250	-250
251	5.109	-29	-251	-251	AN123911	AN124011	-251	-251	-251	-251
252	5.234	-30	-252	-252	AN123912	AN124012	-252	-252	-252	-252
253	5.359	-31	-253	-253	AN123913	AN124013	-253	-253	-253	-253
254	5.484	-32	-254	-254	AN123914	AN124014	-254	-254	-254	-254
255	5.609	-33	-255	-255	AN123915	AN124015	-255	-255	-255	-255
256	5.734	-34	-256	-256	AN123916	AN124016	-256	-256	-256	-256
257	5.859	-35	-257	-257	AN123917	AN124017	-257	-257	-257	-257
258	5.984	-36	-258	-258	AN123918	AN124018	-258	-258	-258	-258
259	6.234	-37	-259	-259	AN123919	AN124019	-259	-259	-259	-259
260	6.484	-38	-260	-260	AN123920	AN124020	-260	-260	-260	-260
261	6.734	-39	-261	-261	AN123921	AN124021	-261	-261	-261	-261
262	6.984	-40	-262	-262	AN123922	AN124022	-262	-262	-262	-262
263	7.234	-41	-263	-263	AN123923	AN124023	-263	-263	-263	-263
264	7.484	-42	-264	-264	AN123924	AN124024	-264	-264	-264	-264
265	7.734	-43	-265	-265	AN123925	AN124025	-265	-265	-265	-265
266	7.984	-44	-266	-266	AN123926	AN124026	-266	-266	-266	-266
267	8.234	-45	-267	-267	AN123927	AN124027	-267	-267	-267	-267
268	8.484	-46	-268	-268	AN123928	AN124028	-268	-268	-268	-268
269	8.734	-47	-269	-269	AN123929	AN124029	-269	-269	-269	-269
270	8.984	-48	-270	-270	AN123930	AN124030	-270	-270	-270	-270
271	9.234	-49	-271	-271	AN123931	AN124031	-271	-272	-271	-271
272	9.484	-50	-272	-272	AN123932	AN124032	-272	-272	-272	-272
273	9.734	-51	-273	-273	AN123933	AN124033	-273	-273	-273	-273
274	9.984	AN6230B-52	-274	-274	AN123934	AN124034	-274	-274	-274	-274
275	10.484						-275		-275	-275
276	10.984						-276		-276	-276
277	11.484						-277		-277	-277
278	11.984						-278		-278	-278
279	12.984						-279		-279	-279
280	13.984						-280		-280	-280
281	14.984						-281		-281	-281
282	15.955 .139									



AS569 UNIFORM DASH NO	NOMINAL DIMENSIONS ID W	AN62278 AN62308	MS28775	MS29561	AN123XXX	AN12XXX	MS9021	MS29513	MS9068	NAS1593 NAS1594
283	16.955									
284	17.955									
325	1.475	.139	AN6227B-28	-325	-325		-325	-325	-325	-325
326	1.660	.139		-2s -326	-326		-326	-326	-326	-326
327	1.725	.210		-30 -327	-327		-327	-327	-327	-327
328	1.850			-31 -326	-328		-328	-328	-328	-328
323	1.915			-32 -329	-329		-329	-329	-329	-329
330	2.100			-33 -330	-330		-330	-330	-330	-330
331	2.225			-34 -331	-331		-331	-331	-331	-331
332	2.350			-35 -332	-332		-332	-332	-332	-332
333	2.475			-36 -333	-333		-333	-333	-333	-333
334	2.600			-37 -334	-334		-334	-334	-334	-334
335	2.725			-38 -335	-335		-335	-335	-335	-335
336	2.650			-3s -336	-336		-336	-336	-336	-336
337	2.375			-40 -331	-337		-331	-331	-331	-337
338	3.100			-41 -338	-338		-338	-338	-338	-338
339	3.225			-42 -339	-339		-339	-339	-339	-339
340	3.350			-43 -340	-340		-340	-340	-340	-340
341	3.415			-44 -341	-341		-341	-341	-341	-341
342	3.600			-45 -342	-342		-342	-342	-342	-342
343	3.125			-46 -343	-343		-343	-343	-343	-343
344	3.850			-47 -344	-344		-344	-344	-344	-344
345	3.975			-46 -345	-345		-345	-345	-345	-345
346	4.100			-4s -346	-346		-346	-346	-346	-346
341	4.225			-50 -347	-341		-341	-347	-341	-341
348	4.350			-51 -343	-348		-348	-348	-348	-348
343	4.415	.210	AN6227B-52	-349	-349		-349	-349	-349	-349
425	4.475	.270	AN6227B-88	-425	-425		-425	-425	-425	-425
426	4.660		AN6227B-53	-426	-426		-426	-426	-426	-426
427	4.725			-54 -427	-427		-421	-421	-427	-421
428	4.656			-55 -428	-428		-428	-428	-428	-428
429	4.915			-56 -429	-429		-429	-429	-429	-429
430	5.100			-51 -430	-430		-430	-430	-430	-430
431	5.225			-58 -431	-431		-431	-431	-431	-431
432	5.350			-5s -432	-432		-432	-432	-432	-432
433	5.475			-60 -433	-433		-433	-433	-433	-433
434	5.600			-61 -434	-434		-434	-434	-434	-434
435	5.725			-62 -435	-435		-435	-435	-435	-435
436	5.850			-63 -436	-436		-436	-436	-436	-436
431	5.915			-64 -431	-437		-437	-431	-431	-437
438	6.225			-65 -438	-438		-438	-438	-438	-438
433	6.415			-66 -439	-439		-439	-439	-439	-439
440	6.125			-67 -440	-440		-440	-440	-440	-440
441	6.975			-66 -441	-441		-441	-441	-441	-441
442	7.225			-69 -442	-442		-442	-442	-442	-442
443	1.415			-70 -443	-443		-443	-443	-443	-443
444	1.725			-71 -444	-444		-444	-444	-444	-444
445	1.975			-12 -445	-445		-445	-445	-445	-445
446	8.415			-13 -446	-446		-446	-446	-446	-446
441	8.915			-74 -441	-441		-447	-447	-441	-441
448	9.475			-15 -448	-448		-448	-448	-448	-448
449	3.375			-16 -449	-449		-449	-449	-449	-449
450	10.475			-77 -450	-450		-450	-450	-450	-450
451	10.975			-78 -451	-451		-451	-451	-451	-451
452	11.475			-19 -452	-452		-452	-452	-452	-452
453	11.915			-80 -453	-453		-453	-453	-453	-453
454	12.415			-81 -454	-454		-454	-454	-454	-454
455	12.975			-82 -455	-455		-455	-455	-455	-455
456	13.415			-83 -456	-456		-456	-456	-456	-456
457	13.975			-84 -451	-451		-451	-451	-457	-451
458	14.475			-85 -458	-458		-456	-458	-458	-458
453	14.975			-86 -459	-459		-459	-453	-459	-459
460	15.475	.275	AN6227B-87	-460	-460		-460	-460	-460	-460

Chart 3B

TEFLON BACKUP RINGS

CROSS REFERENCE PART NUMBERS AND DIMENSIONS

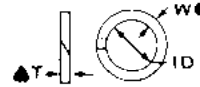
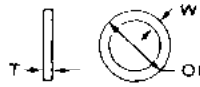
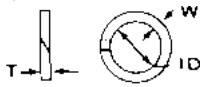

AS 568 UNIFORM DASH NO.	MS28774			DASH NO.	MS27595			LS4565 OR LS4564	ID	MS28782 or MS28783 (AN6246 Dash Nos. Same as MS28782)
	ID	T	W		OD	T	W			
-004	.109	.049	.052	-004	.190	.050	.055			
-005	.124			-005	.221					
-006	.140			-006	.235			LS4565-1	.125	MS28782-1
-007	.171			-007	.266			-2	.156	-2
-008	.202			-008	.297			-3	.188	-3
-009	.234			-009	.329			-4	.219	-4
-010	.265			-010	.360			-5	.250	-5
-011	.327			-011	.422			-6	.312	-6
-012	.390			-012	.485			LS4565-7	.375	MS28782-7
-013	.455			-013	.550					
-014	.518			-014	.613					
-015	.580			-015	.675					
-016	.643			-016	.738					
-017	.705			-017	.800					
-018	.768			-018	.863					
-019	.830			-019	.925					
-020	.898			-020	.991					
-021	.960			-021	1.053					
-022	1.023			-022	1.116					
-023	1.085			-023	1.178					
-024	1.148			-024	1.241					
-025	1.210			-025	1.303					
-026	1.273			-026	1.366					
-027	1.335			-027	1.428					
-028	1.398		.052	-028	1.491		.055			
-110	.390		.086	-110	.550		.0	LS4565-8	.375	MS28782-8
-111	.452			-111	.613			-9	.437	-9
-112	.515			-112	.675			-10	.500	-10
-113	.577			-113	.738			-11	.562	-11
-114	.640			-114	.800			-12	.625	-12
-115	.702			-115	.863			-13	.688	-13
-116	.765			-116	.925			LS4565-14	.750	MS28782-14
-117	.832			-117	.991					
-118	.895			-118	1.053					
-119	.957			-119	1.116					
-120	1.020			-120	1.178					
-121	1.082			-121	1.241					
-122	1.145			-122	1.303					
-123	1.207			-123	1.366					
-124	1.270			-124	1.428					
-125	1.332			-125	1.491					
-126	1.397			-126	1.553					
-127	1.459			-127	1.616					
-128	1.522			-128	1.678					
-129	1.584			-129	1.741					
-130	1.647			-130	1.805					
-131	1.709			-131	1.867					
-132	1.772			-132	1.930					
-133	1.834			-133	1.992					
-134	1.897			-134	2.055					
-135	1.959			-135	2.118					
-136	2.022			-136	2.180					
-137	2.084			-137	2.243					
-138	2.147			-138	2.305					
-139	2.209	.049	.086	-139	2.368					
-140	2.258	.049	.086	-140	2.430					
-141	2.320			-141	2.493					
-142	2.383			-142	2.555					
-143	2.445			-143	2.618					
-144	2.508			-144	2.680					
-145	2.570			-145	2.743					
-146	2.633			-146	2.805					
-147	2.695			-147	2.868					
-148	2.758			-148	2.930					
-149	2.820	.049	.086	-149	2.993	.050	.088			

MS28774 IN
THESE SIZES
DISCONTINUED
SEE MS27595

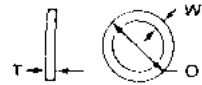
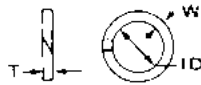

AS568 UNI FORM DASH NO.	MS28774			DASH NO.	MS27595			LS4565 OR LS4564	ID	MS28782 or MS8783 (AN6246 Dash Non SAME AS MS28782)
	ID	T	W		OD	T	W			
-210	.766	.049	.119	-210	.991	.051	.119	LS4565-15	.750	MS28782-15
-211	.828			-211	1.053			-16	.812	-16
-212	.891			-212	1.116			-17	.875	-17
-213	1.953			-213	1.178			-18	.937	-18
-214	1.016			-214	1.241			-19	1.000	-19
-215	1.078			-215	1.303			-20	1.062	-20
-216	1.141			-216	1.366			-21	1.125	-21
-217	1.203			-217	1.428			-22	1.187	-22
-218	1.266			-218	1.491			-23	1.250	-23
-219	1.334			-219	1.553			-24	1.312	-24
-220	1.397			-220	1.616			-25	1.375	-25
-221	1.459			-221	1.678			-26	1.437	-26
-222	1.522			-222	1.741			LS4565-27	1.500	MS28782-27
-223	1.647			-223	1.867			LS4564-1	1.625	MS28783-1
-224	1.772			-224	1.992			-2	1.750	-2
-225	1.897			-225	2.118			-3	1.875	-3
-226	2.022			-226	2.243			-4	2.000	-4
-227	2.147			-227	2.368			-5	2.125	-5
-228	2.272			-228	2.493			-6	2.250	-6
-229	2.397			-229	2.618			-7	2.375	-7
-230	2.522	.049	.119	-230	2.743			-8	2.500	-8
-231	2.631	.049	.118	-231	2.868			-9	2.625	-9
-232	2.756			-232	2.993			-10	2.750	-10
-233	2.881			-233	3.118			-11	2.875	-11
-234	3.006			-234	3.243			-12	3.000	-12
-235	3.131			-235	3.368			-13	3.125	-13
-236	3.256			-236	3.493			-14	3.250	-14
-237	3.381			-237	3.618			-15	3.375	-15
-238	3.506			-238	3.743			-16	3.500	-16
-239	3.631			-239	3.868			-17	3.625	-17
-240	3.756			-240	3.993			-18	3.750	-18
-241	3.881			-241	4.118			-19	3.875	-19
-242	4.006			-242	4.243			-20	4.000	-20
-243	4.131			-243	4.368			-21	4.125	-21
-244	4.256			-244	4.493			-22	4.250	-22
-245	4.301			-245	4.618			-23	4.375	-23
-246	4.506			-246	4.743			-24	4.500	-24
-247	4.631	.049	.118	-247	4.868	.050	.119	LS4564-25	4.625	MS28783-25
-325	1.513	.070	.183	-325	1.867	.073	.185	LS4565-28	1.500	MS28782-28
-326	1.638			-326	1.992			-29	1.625	-29
-327	1.763			-327	2.118			-30	1.750	-30
-328	1.888			-328	2.243			-31	1.875	-31
-329	2.013			-329	2.368			-32	2.000	-32
-330	2.138			-330	2.493			-33	2.125	-33
-331	2.268			-331	2.618			-34	2.250	-34
-332	2.393			-332	2.743			-35	2.375	-35
-333	2.518			-333	2.868			-36	2.500	-36
-334	2.643			-334	2.993			-37	2.625	-37
-335	2.768			-335	3.118			-38	2.750	-38
-336	2.893			-336	3.243			-3s	2.875	-39
-337	3.018			-337	3.368			-40	3.000	-40
-338	3.143			-338	3.493			-41	3.125	-41
-339	3.273			-339	3.618			-42	3.250	-42
-340	3.398			-340	3.743			-43	3.375	-43
-341	3.523			-341	3.868			-44	3.500	-44
-342	3.648			-342	3.993			-45	3.625	-45
-343	3.773			-343	4.118			-46	3.750	-46
-344	3.898			-344	4.243			-47	3.875	-47
-345	4.028			-345	4.368			-48	4.000	-48
-346	4.153			-346	4.493			-49	4.125	-4s
-347	4.278			-347	4.618			-50	4.250	-50
-348	4.403			-348	4.743			-51	4.375	-51
-349	4.528	.070	.183	-349	4.868	.073	.185	-52	4.500	-52
-425	4.551	.105	.026	-425	4.974	.108	.236	-88	4.500	-88
-426	4.676		I	-426	5.099			LS4565-53	4.625	MS28782-53

MS28774 IN
THESE SIZES
DISCONTINUED.
SEE MS27595

3B CONTINUED		TEFLON BACKUP RINGS CROSS REFERENCE PART NUMBERS AND DIMENSIONS								
AS 568 UNIFORM DASH NO.	MS28774			DASH NO.	MS27595			LS4565 OR LS4564	ID	MS28782 or MS28783 IAN6246 Dash Nos. Same as MS28782)
	ID	T	W		OD	T	W			
-427	4.801	.105	.026	-427	5.224	.10	.2	LS4565-54	4.750	MS28782-54
-428	4.926	↑	↓	-428	5.349	↑	↓	-55	4.875	-55
-429	5.051			-429	5.474			-56	5.000	-56
-430	5.176			-430	5.599			-57	5.125	-57
-431	5.301			-431	5.724			-58	5.250	-58
-432	5.426			-432	5.849			-59	5.375	-59
-433	5.551			-433	5.974			-60	5.500	-60
-434	5.676			-434	6.099			-61	5.625	-61
-435	5.801			-435	6.224			-62	5.750	-62
-436	5.926			-436	6.349			-63	5.875	-63
-437	6.051			.105	.026			-437	6.474	-64
-438	6.274	.105	.236	-438	6.724	-65	6.250	-65		
-439	6.524	MS28774 IN THESE SIZES DISCONTINUED. SEE MS27595	-439	6.974	-66	6.500	-66			
-440	6.774		-440	7.224	-67	6.750	-67			
-441	7.024		-441	7.474	-68	7.000	-68			
-442	7.274		-442	7.724	-69	7.250	-69			
-443	7.524		-443	7.974	-70	7.500	-70			
-444	7.774		-444	8.224	-71	7.750	-71			
-445	8.024		-445	8.474	-72	8.000	-72			
-446	8.524		-446	8.974	-73	8.500	-73			
-447	9.024		-447	9.474	-74	9.000	-74			
-448	9.524		-448	9.974	-75	9.500	-75			
-449	10.024	-449	10.474	-76	10.000	-76				
-450	10.524	-450	10.974	-77	10.500	-77				
-451	11.024	-451	11.474	-78	11.000	-78				
-452	11.524	-452	11.974	-79	11.500	-79				
-453	12.024	-453	12.474	-80	12.000	-80				
-454	12.524	-454	12.974	-81	12.500	-81				
-455	13.024	-455	13.474	-82	13.000	-82				
-456	13.524	-456	13.974	-83	13.500	-83				
-457	14.024	-457	14.474	-84	14.000	-84				
-458	14.524	-458	14.974	-85	14.500	-85				
-459	15.024	-459	15.474	-86	15.000	-86				
-460	15.524	.105	.236	-460	15.974	.108	.236	LS4565-87	15.500	MS28782-87

13

Chart 3C		TUBE FITTING TO BOSS CROSS REFERENCE PART NUMBERS, TUBE SIZES, AND DIMENSIONS													
AS 568 UNIFORM DASH NO.	TUBE SIZE OD	ID	W	LS4634	NAS 1596 MS29512	MS28778 MS9020	TUBE SIZE OD	LS4 764	ID	T	W	MS9058 MS28773	ID	T	W
902	1/8	.239	.064	-3	-3	-02	1/8					-03	.309	.056	.112
903	3/16	.301	.064	-4	-4	-03	3/16	-3	.308	.045	.116	-04	.360	.061	.117
904	1/4	.351	.078	-5	-5	-04	1/4	-4	.360	.051	.117	-05	.423	.061	.117
905	5/16	.414	.072	-6	-6	-05	5/16	-5	.423	.051	.117	-06	.478	.061	.121
906	3/8	.468	.078	-7	-7	-06	3/8	-6	.478	.051	.121	-07	.549	.061	.121
907	7/16	.530	.082	-8	-8	-07	7/16	-7				-08	.656	.061	.125
908	1/2	.644	.087	-9	-9	-08	1/2	-8	.656	.051	.125	-09	.718	.061	.125
909	9/16	.706	.097	-10	-10	-09	9/16	-9				-10	.769	.073	.131
910	5/8	.755	.097	-11	-11	-10	5/8	-10	.769	.063	.131	-11	.878	.073	.159
911	11/16	.863	.116	-12	-12	-11	11/16	-11				-12	.941	.073	.169
912	3/4	.924	.116	-14	-14	-12	3/4	-12	.941	.063	.170				
914	7/8	1.047	.116	-16	-16	-14	7/8								
916	1	1.171	.116	-20	-20	-16	1	-16	1.191	.063	.168	-16	1.191	.073	.169
920	1-1/4	1.475	.118	-24	-24	-20	1-1/4	-20	1.503	.063	.169	-20	1.503	.073	.169
924	1-1/2	1.720	.118	-28	-28	-24	1-1/2	-24	1.752	.063	.169	-24	1.752	.073	.169
928	1-3/4	2.090	.118	-32	-32	-28	1-3/4	-28	2.127	.063	.169	-28	2.127	.073	.169
932	2	2.337	.118	-32	-32	-32	2	-32	2.377	.063	.169	-32	2.377	.073	.169

1 Dash numbers correspond to those of AN6290 gasket. MS28778 supersedes and is equal to AN6290.

2. All dimensions in inches.



SEALS BY GREENE. TWEED & COMPANY

One of the newer, somewhat specialized designs for packings departs from the conventional O-ring cross section to form a T shaped cross section. The manufacturer, Greene, Tweed & Company, calls packings of this design **G-T® Rings**.

The G-T Ring arrangement prevents rolling of the packing and does an excellent job of sealing. The two backup rings carry most of the load. The unique feature in this new packing is the T shape of the rubber sealing material which can be molded from any of the standard materials. The backup rings are Teflon. This T shaped packing is never used without the two backup rings as shown in Figure 1.

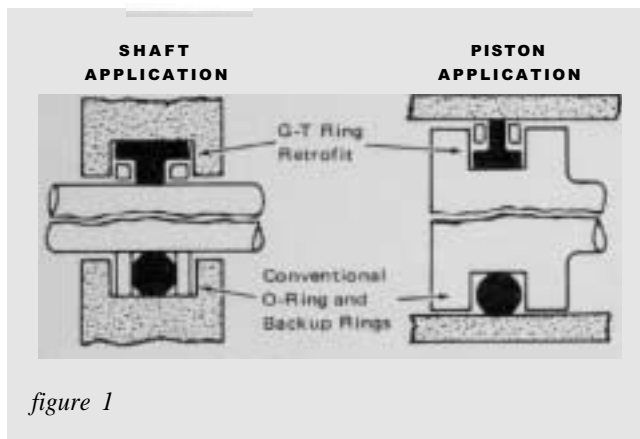

figure 1

The two special backup rings are necessary to complete the G-T Ring seal assembly. These backup rings are preformed to fit into the spaces on each side of the stem of the T, making it practically impossible for the rubber ring to roll or to extrude even under extreme conditions of dryness and high pressure (Figure 2).

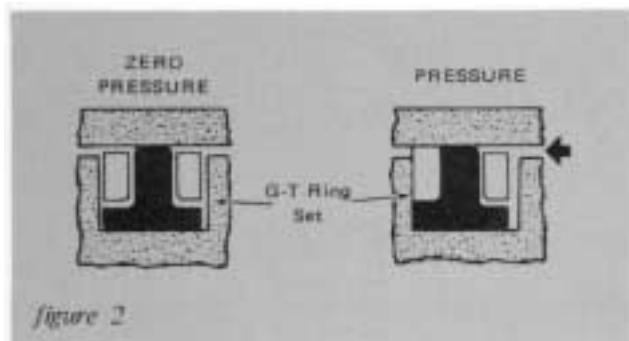

figure 2

The G-T Ring was originally tested by Lockheed-Georgia Company for application in the Hercules ramp actuating cylinder. This cylinder had always been plagued by rolling O-rings because of two factors: (1) the rod is excessively long so we are dealing with a very long stroke; (2) the ramp, when open, exposes this long rod to the drying effect of the atmosphere. These two conditions caused

excessive seal rolling in this actuator. Since the change to Greene, Tweed & Company seals, we have had no reported cases of seal rolling.

The G-T Ring seal proved to be vastly superior to any other seal tested. Its success in the tough application on the ramp actuators subsequently led to its installation on all of our long and medium stroke hydraulic actuators.

The following is a breakdown of the manufacturer's part number structure for Greene, Tweed & Company seals:

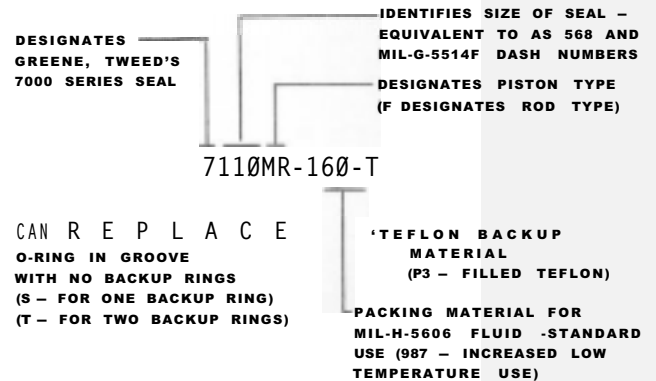

The makeup of a part number for a G-T Ring listed in a special kit may be different from that shown in our example. For instance, the shaft seal in the JetStar MLG actuator is P/N 222FT-160A-T. This number retains most of the characteristics of our example. The numbers for the Hercules ramp actuator shaft seal are unique in form; also, the packing and backup rings are numbered separately (reference G-T Ring Chart). Notice that G-T Ring part numbers are inconsistent with military specification numbers; in fact, early G-T numbers are inconsistent with present day numbers.

Our brief analysis of the manufacturer's part number makeup for G-T Ring assemblies is intended to help you become generally familiar with them. You can make comparisons to see how this unique G-T Ring design fits in with the O-ring inventory if you know the width of the groove provided for the O-ring. Does the original groove accommodate no backups, one backup or two backups? Lockheed recommends (as does the manufacturer) that you get engineering assistance before you substitute a G-T Ring for a conventional seal.

GREENE, TWEED SEALS USED IN THE HERCULES

The following is a partial listing of those Hercules components using G-T Rings, along with the part number for the seals. Only the G-T Rings are listed. Consult the applicable overhaul manuals for the components to finish out the list of seals needed and the procedures for replacing the seals.

G-T RING CHART

COMPONENT	PART NUMBER	G-T RING SET PART NUMBER
Aft Cargo Door Actuator	370749-1	721 D5FT-987-P3
Ramp Actuator	370750-1	32A8FT-160A Rubber Packing 32A8FT-2T Backup Ring (2 ea)
Snubber-Aft Cargo Door	5C5794 (Ronson)	7329MT-160-N 7222MT-160-N 7215FT-160-N 7112FT-160-N
Snubber-Aft Cargo Door	* 7-3544 (Weston Hydraulics)	7329MT-160A-N 7222MT-160A-N 7215FT-160A-N 7112FT-160A-N
Rudder Booster Actuator	5C5792 (Ronson)	7214FT-160-T
Aileron Booster Actuator	5C5791 (Ronson)	7216FT-160-T
Nose Landing Gear Actuator	3400770	7329FT-987-T
Nose Landing Gear Shock Strut	3303591	** ** 734B5FT-987-4780 734F8MT-987-N
Main Landing Gear Shock Strut	388058	** ** 743A7 FT-987-4780 743A9MT-987-N
Main Landing Gear Gearbox	8348M1 (CALCO)	7342MS-160-P5 7343MS-160-P5
Main Landing Gear Gearbox	* 695579-69 (Western Gear P/N 1051 R300)	34D8FT-160-A-N 34C9FT-160-A-N
Single Disc Brake - MLG	* 9540918 95550071 9550402	723C8F R-987-P4 33A7 MS-1 60-4P
<p>* Out of production.</p> <p>** Also included in cure date kits for replacement in all previously supplied nose and main gear struts.</p>		

SERVICING HERCULES HYDRAULIC FILTERS

In answer to a request from the field, the part numbers for seals and rings for Hercules hydraulic filters have been organized into one table for easy reference. New seals and rings are to replace the old ones each time the filter elements are serviced. (See page 16 for chart.)

Some drawings carry AN (Air Force-Navy) part numbers which later changed to MS (Military Standard) numbers. In these cases we include both numbers. One of the parts for the engine pressure filter has a vendor part number because it is not interchangeable with similar parts manufactured to industry standard drawings.

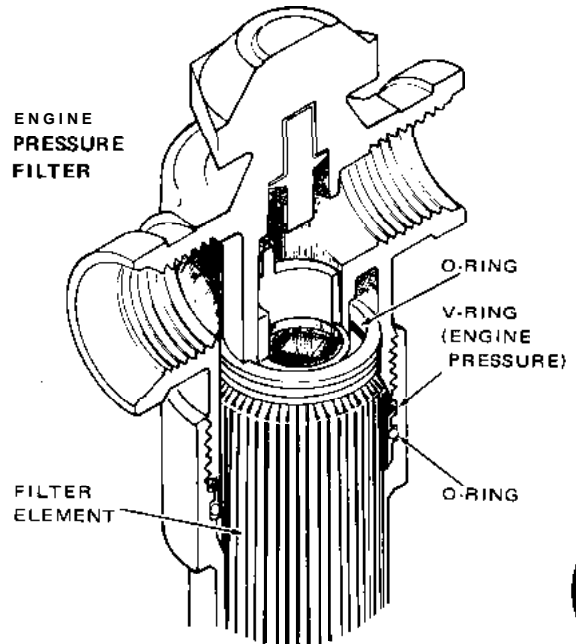

SEALS FOR SERVICING HERCULES HYDRAULIC FILTERS

FILTER	REQUIRED	MS PART NUMBER	AN OR VENDOR PART NUMBER
BOOSTER CASE DRAIN			
O-Ring	1	MS28775-222	AN6227B-27
Backup Ring	2	MS28774-222	AN6246-27 (leather)
BOOSTER MAIN RETURN			
O-Ring	1	MS28775-227	AN6230B-5
Backup Ring	2	MS28774-227	AN6244-5
UTILITY CASE DRAIN			
O-Ring	1	MS28775-227	AN6230B-5
Backup Ring	2	MS28774-227	AN6244-5
UTILITY MAIN RETURN			
O-Ring	1	MS28775-116	
O-Ring	1	MS28775-223	
Backup Ring	2	MS28774-223	
AUXILIARY RETURN			
O-Ring	1	MS28775-226	AN6230B-4
Backup Ring	2	MS28774-226	AN6244-4
AUXILIARY PRESSURE			
O-Ring	1	MS28775-226	AN6230B-4
Backup Ring	2	MS28774-226	AN6244-4
ENGINE PRESSURE			
(One per engine)			
D-Ring	1	MS28775-018	
O-Ring	1	MS287 75-028	
V-Ring (Aircraft Porous Media)	1		AA-2291-10D9
AILERON UTILITY			
O-Ring	1	MS28775-214	AN6227B-19
O-Ring	1	MS28775-228	AN6230B-6
Back up Ring	2	MS28774-228	LS4564-6
AILERON BOOSTER			
O-Ring	1	MS28775-214	AN6227B-19
O-Ring	1	MS28775-228	AN6230B-6
Backup Ring	2	MS28774-228	LS4564-6
RUDDER UTILITY			
O-Ring	1	MS28775-212	
O-Ring	1	MS287 7 5-226	
Backup Ring	1	MS28774-226	
RUDDER BOOSTER			
O-Ring	1	MS28775-212	
O-Ring	1	MS28775-226	
Backup Ring	1	MS28774-226	
ELEVATOR BOOSTER			
O-Ring	1	MS28775-114	
O-Ring	1	MS28775-222	
Backup Ring	2	MS28774-222	
ELEVATOR UTILITY			
O-Ring	1	MS28775-114	
O-Ring	1	MS28775-222	
Backup Ring	2	MS28774-222	



SERVICING INSTRUCTIONS FOR HYDRAULIC FILTERS

- Empty all contaminants from bottom of filter bowl.
- Rinse bowl with clean MIL-H-5606 hydraulic fluid (red oil).
- Inspect new O-ring to ensure that it is not nicked or chipped.

Lubricate O-ring with clean MIL-H-5606.

- Install O-ring and backup rings being very careful not to nick or pinch the O-ring – remember, most seal leaks are caused by damage at installation.
- Lubricate the threads on the bowl and housing head with MIL-H-5606.
- Fill engine pressure line filter bowl with fluid to displace air.
- Screw bowl into head again being careful that seals are properly seated prior to assembly.
- Pressure check during normal function of system.

NOTE

Reuse of packings and gaskets is considered poor maintenance practice. Mutilate and discard all removed (used) packings and gaskets.

CARE AND HANDLING OF PREFORMED PACKINGS

Preformed packings can do their job of sealing only if they are given proper care and handling in storage, removal, and installation. Here are some tips on handling packings:

- Packings can become deformed as a result of poor storage – don't stack parts and containers in a manner that will damage the seals.
- Creasing of seals results from force applied by sharp edges and by squeezing between boxes.
- Flattening of seals can result from storing under heavy parts.
- Deformation of seals can result from hanging packings on nails or pegs.
- Contamination can result from leaking fluids, dirt, etc., coming in contact with the seals.
- Keep packings in their containers until used.
- Be mindful of cure date and shelf life.
- Use the correct tool in the removal and installation of packings. A variety of tools may be used for a given job. Aluminum, brass, phenolic, plastic or other suitable soft material may be used to make the tools. Avoid sharp edges, and be careful of nicks and scratches on the component such as rod ends, caps, pistons, where the seal fits.

17

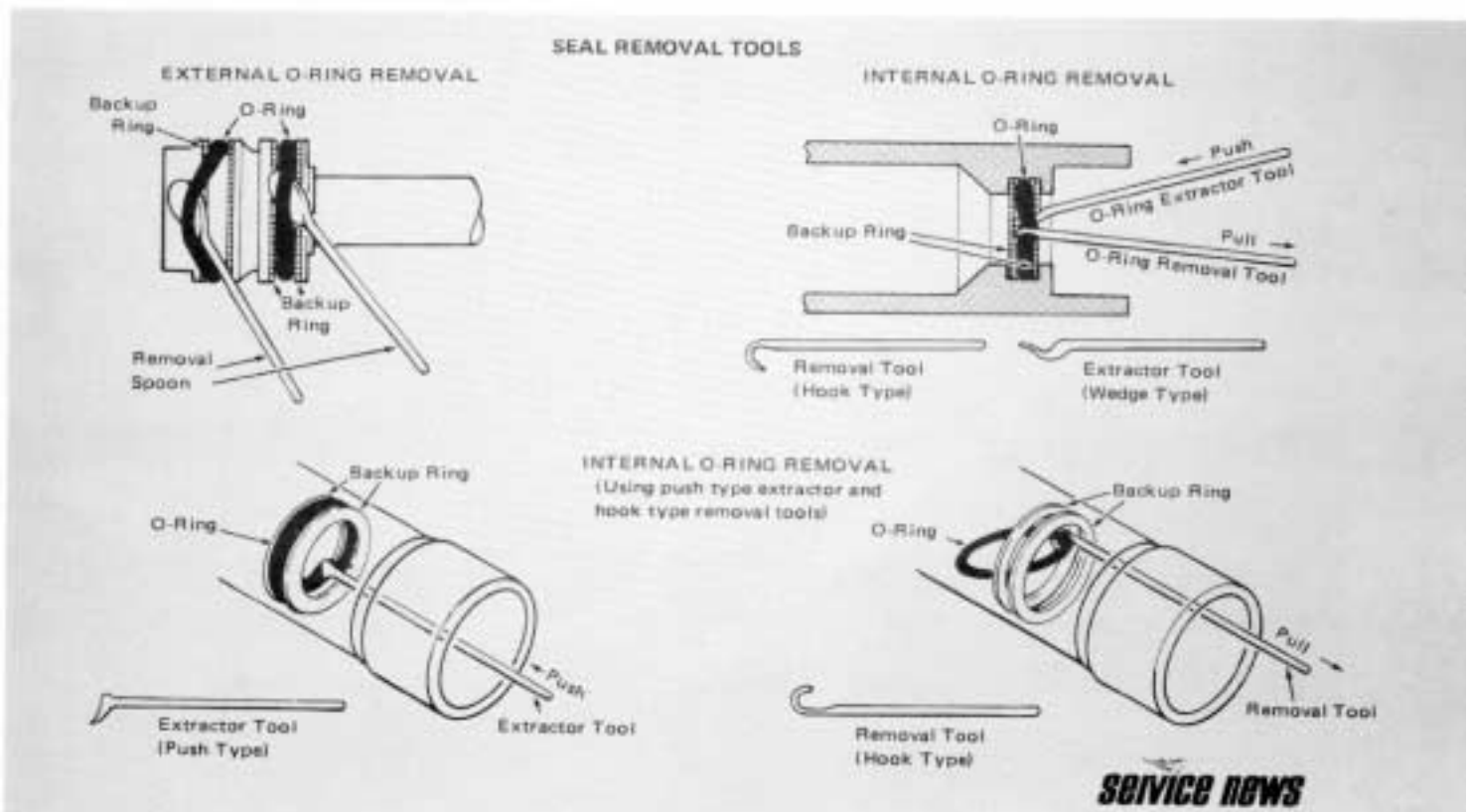

nose wheel SHIMMY

and what to do about it

by Bob McRay, Service Representative

Most Hercules maintenance personnel know that there are at least fifteen items on a Hercules nose landing gear that can cause or contribute to nose wheel shimmy. The problem is how to go about isolating the shimmy to an item, component, or area without expending considerable time and effort on costly trial and error replacements and adjustments.

18

One method that is simple, accurate, relatively easy, and has been used quite successfully in the field requires the assistance of a flight crew, and entails only a taxi run during which a couple of observations are made and recorded. It is accomplished as follows:

Taxi at a speed just sufficient to allow the nose wheels to be lifted off the ground (just a few seconds will do), and make these notations:

- (1) Did the shimmy stop while the nose wheels were off the ground or did it continue?
- (2) During the taxi run with the wheels on the ground did the steering wheel pointer move back and forth rapidly during shimmy or was it relatively steady?

CAUTION

IF REPEATED TAXI RUNS ARE NECESSARY,
BRAKES SHOULD BE ALLOWED TO COOL
BETWEEN RUNS.

That's it. Taxi back to the work area and look at your notes.

If the shimmy continued with the wheels off the ground, wheel and/or tire unbalance is indicated. Check for worn spots on the tires and any other condition on the wheels

or tires that may contribute to an unbalanced condition. Recaps, if used at your facility, should be highly suspect, since it is a difficult task to balance recapped tires.

If the shimmy ceased at nose liftoff, then observations noted in item (2) during the taxi run must be considered:

- *If the shimmy produced no noticeable movement at the steering wheel pointer with wheels on the ground, looseness, caused by excessive wear in certain mechanical areas, is indicated. First, check the torque arms (scissors). The upper, lower, and center attach bolts and bushings are subject to wear and, if the wear is excessive, will cause a violent shimmy at all speeds up to liftoff. Special attention should be given to the fact that one bolt and/or bushing location may be within the wear tolerances, but it is the sum of the wear on all the associated bolts and bushings that should be of concern. Next, check the steering actuators' rod end bearings for wear and the bolts for security of mounting. Last, and this will require jacking the nose of the aircraft, check for worn wheel bearings and proper axle nut torque.*
- *If the steering wheel pointer did move back and forth during the shimmy, a problem concerning the steering control valve is indicated. Here's why: The steering control valve is unique in that it will accept steering commands from either the steering wheel or from the nose gear, permitting certain types of shimmy to be fed back through the valve to the steering pointer. Since the pointer is connected directly to the steering control valve shaft by the rocker arm and cables, it will be displaced anytime the shaft is displaced. Steering wheel pointer movement during shimmy narrows our check to two areas: tires and the control valve.*

(1) **Check the tires.** Uneven tire pressures and dissimilar or faulty tread designs tend to make a tire move in irregular patterns. This irregular movement is transmitted through the scissors to the control valve and, as speed increases, so does the irregular movement, or shimmy.

(2) **Next, check the valve itself.** The relief valve, P/N 341640, could be sticking in the open position due to burrs on the stem. (T.O. 4SA3-26-3 has been amended to include rework of this stem during overhaul.) One method of checking for this condition is to remove the plug (item 4, Figure 3, T.O. 4SA3-26-3 dated 20 January 1975) in the manifold side of the steering valve and install an MS 21916D6-4 reducer, MS28762-4 hose, P/N 695767-1 snubber, appropriate adapter, and a 0-500 PSI pressure gage (see illustration). Disconnect the scissors and, using hydraulic pressure from the auxiliary system, rotate the steering mechanism by turning the steering wheel at a very slow but constant rate of turn from center to extreme. This should take approximately 10 seconds. Pressure on the gage should be maintained at 70 PSI plus or minus 20 PSI.

Pressure readings outside these limits indicate a sticky or leaking relief valve assembly. Since the valve is an integral

part of the spring loaded accumulator, it requires replacement of the complete steering control valve.

That's the troubleshooting procedure. It may sound lengthy and difficult, but if you concern yourself with the mechanics of the overall nose gear and its relationship to the steering mechanism, it's as easy as 1,2,3.

To sum up:

- (1) Shimmy with wheels off the ground - tire and wheel unbalance.
- (2) Shimmy with wheels on the ground and no pointer movement - bolts, bushings and bearings wear.
- (3) Shimmy with wheels on the ground with pointer movement - steering control valve, uneven tire pressures, tread imperfections, or unlike tread designs.

One last thing - and I'll bet you caught it - the taxi check could be eliminated if the flight crew would make these observations for you when the problem occurs, and note them in the flight forms.

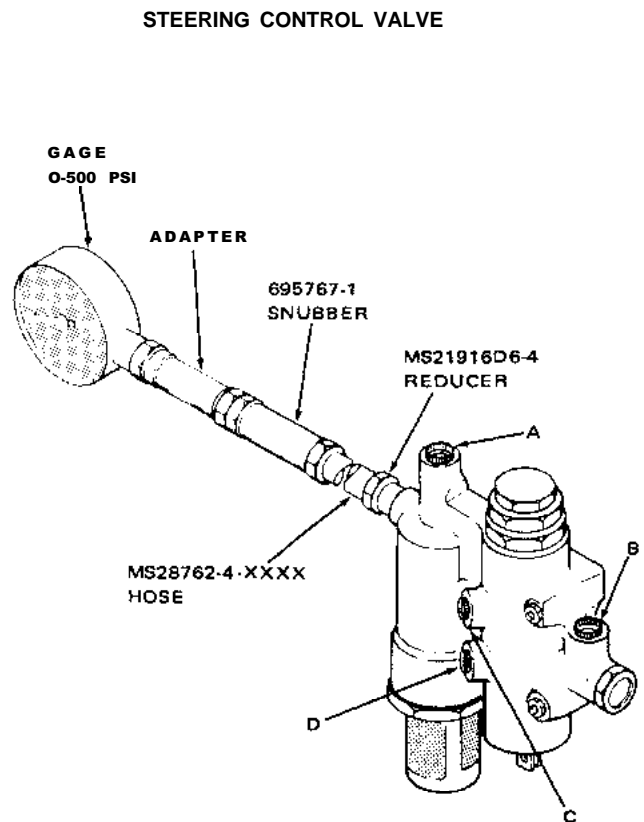
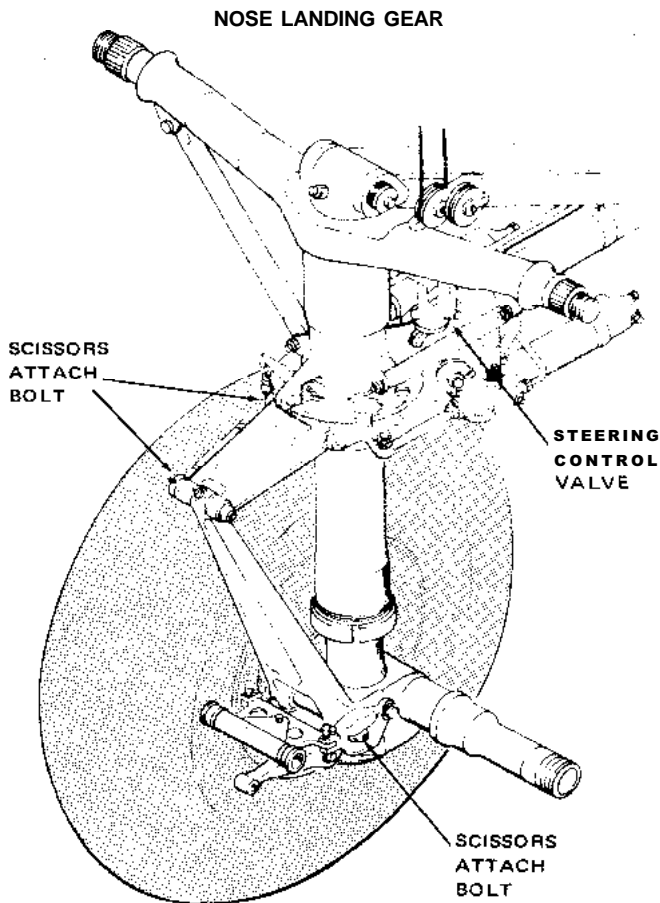

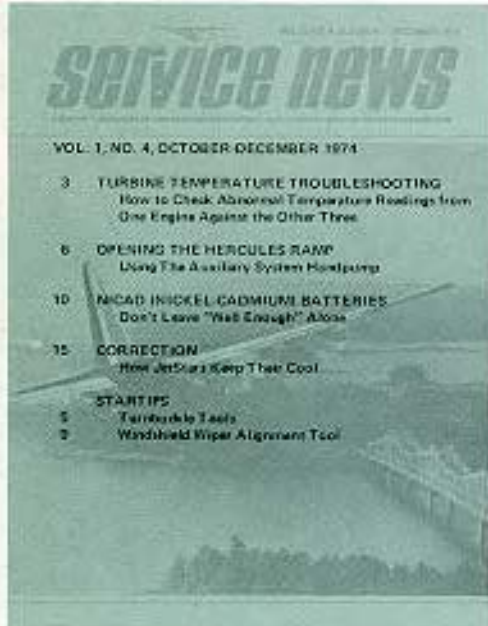
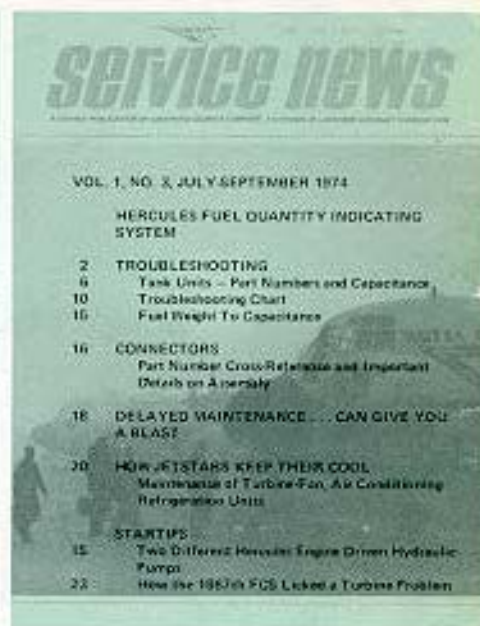

INDEX
1974
 THROUGH
1975

