



# Service News

A SERVICE PUBLICATION OF LOCKHEED MARTIN AERONAUTICAL SYSTEMS SUPPORT COMPANY



**INSIDE THE C-130J**

**POWER PLANT HOSES**

# Service News

A SERVICE PUBLICATION OF  
 LOCKHEED MARTIN AERONAUTICAL  
 SYSTEMS SUPPORT COMPANY

Editor  
 Charles I. Gale

Vol. 24, No. 1, July - September 1997

**CONTENTS**

- 2 Focal Point**  
 LMASSC's Business Development and Field Support units team up to provide the best in total customer support.
- 3 All About Power Plant Hoses**  
 Both Teflon and elastomeric hoses are used to connect power plant components in C-130H and earlier Hercules. This article explains what goes where.
- 7 Inside the C-130J**  
 A special center section featuring a detailed cutaway drawing of the newest Hercules airlifter.
- 13 Propeller Reindexing Safety**  
 Careful control of engine torque will ensure propeller reindexing safety, even at sea level during wintertime.
- 14 1997 Hercules Operators Conference**  
 October 13, 1997 is the starting date for this year's HOC. You'll find all the conference details here, and even a preregistration form. Please join us!

**Front Cover:** The Royal Air Force leads the way as the launch customer of the C-130J.

**Back Cover:** A C-130J in a maximum-effort takeoff during flight testing.

Photographic support by John Rossino and Rita King.

Service News is published by Lockheed Martin Aeronautical Systems Support Company, a subsidiary of Lockheed Martin Corporation. The information contained in this issue is considered to be accurate and authoritative; it should not be assumed, however, that this material has received approval from any governmental agency or military service unless specifically noted. This publication is intended for planning purposes only, and must not be construed as authority for making changes on aircraft or equipment, or as superseding any established operational or maintenance procedures or policies. Written permission must be obtained from Lockheed Martin Aeronautical Systems Support Company before republishing any material in this periodical. Copyright 1997, Lockheed Martin Corporation.

Address all communications to Editor, Service News, Lockheed Martin Aeronautical Systems Support Company, 2251 Lake Park Drive, Smyrna, GA 30080-7605. Telephone 770-431-6544; Facsimile 770-431-6556. Internet e-mail may be sent to cigale@mar.lmco.com.

## Focal Point

### It's All in the Teamwork

It would be difficult to find an area of human endeavor that is more dependent upon teamwork for success than aviation. It is significant that mankind's first conquest of the air was not achieved by an isolated visionary laboring in seclusion. Instead, the initial success came through the combined efforts of two gifted bicycle mechanics from Ohio, working with a team of helpers and friends on a windswept beach in North Carolina.



We at Lockheed Martin Aeronautical Systems Support Company (LMASSC) have never lost sight of the importance of just that kind of teamwork in the way we operate our business. It is no coincidence that LMASSC is organized as a close partnership of two teams of specialists, both fully committed to meeting the total support needs of our customers.

Each of the LMASSC organizations has its own special areas of expertise and responsibilities. Business Development, led by George Lowe, is the marketing arm for LMASSC and as such provides a remarkably broad range of customer support products. These include a comprehensive spares provisioning program that offers new and overhauled spare parts and support/test equipment, rebuilt parts, an innovative parts exchange program, and complete component repair and overhaul. Business Development is also able to meet operator requirements for technical manuals, training equipment, an extensive line of O.E.M. - approved modification kits, and complete turn-key Contractor Logistics Support (CLS) packages.



The Field Support side of LMASSC, led by Jim Adams, has the responsibility for providing all support services, such as on-site Field Service Representatives, field modification teams, on-site aircrew and maintenance training, aircraft preservation, and technical assistance with heavy maintenance of all types. Field Support can also provide technical support for damage assessment and major inspections for a wide variety of Lockheed Martin-built aircraft. These include the C-130/L-100 Hercules, C-141 StarLifter, C-5 Galaxy, P-3 Orion, S-3 Viking, L-1011 TriStar, JetStar, and the L-188 Electra.

The mutually supportive partnership that characterizes the operations within LMASSC is in many ways a reflection of the kind of relationship we are striving to build with operators in every corner of the globe. LMASSC is a unique company in that it was designed from the very first day to meet the total support needs of our customers. We believe we have been able to meet most of their needs and expectations, but we will not be satisfied until we are able to meet them all. For us, it is not only a matter of good business, but it goes to the essence of what it takes to help ensure the success of everyone who operates a Lockheed Martin aircraft. In the final analysis, it's all in the teamwork. We cordially invite you to become part of the team. Just give us a call!

**Business Development**  
**G. M. Lowe**  
**Tel: 770-431-6660**  
**Fax: 770-431-6666**  
**e-mail: gmlowe@mar.lmco.com**

**Field Support**  
**J. D. Adams**  
**Tel: 770-431-6500**  
**Fax: 770-431-6556**  
**e-mail: jdadams@mar.lmco.com**

LOCKHEED MARTIN AERONAUTICAL  
 SYSTEMS SUPPORT COMPANY

J. L. GAFFNEY – PRESIDENT

FIELD SUPPORT  J. D. ADAMS	BUSINESS DEVELOPMENT  G. M. LOWE
-------------------------------------	---



Teflon, Elastomeric, – What Goes Where?

# ALL ABOUT POWER PLANT HOSES

by Wayne Thompson, Field Support Analyst, Senior  
Lockheed Martin Aeronautical Systems Support Company

There seems to be considerable confusion about the Teflon and elastomeric hoses used with the power plants of Hercules aircraft prior to the C-130J. The number of inquiries received by both Allison and Lockheed Martin regarding these hoses indicates that a significant amount of misunderstanding exists as to who supplies these components, and to which subassemblies specific hoses belong.

First, let us clarify what we mean by engine hoses. The engine, which was manufactured by the Allison Engine Company, is the bare engine as it comes out of the shipping container. It comes equipped with all Teflon hoses, supplied by the engine manufacturer.

Second, there is the quick engine change (QEC), manufactured by Rohr Industries. It is the housing surrounding the engine, and includes the cowling, oil tank, and the other plumbing which facilitates the mounting of the engine to the aircraft. Most of the hoses used in the QEC are elastomeric (rubber), but a few are Teflon.

Finally, there is the aft nacelle. The aft nacelle is the part of the aircraft wing located at the point where the engine and QEC attach to the airframe. As in the case of the QEC, most hoses used in the aft nacelle are of elastomeric construction. Here again though, there also are some hoses of Teflon construction.

Now that we have identified the principal power plant subassemblies that apply in connection with hose applications, we can list them separately. Listing them in this way will help eliminate the confusion that comes from lumping all the ‘engine, QEC, and nacelle hoses together and calling them all simply “engine hoses.”

## Engine Hoses

The following listing shows the hoses that come with the Allison engine as shipped in the container from the factory. All the hoses provided with the engine are Teflon hoses. They have no time-change requirements and are changed on the basis of condition only.

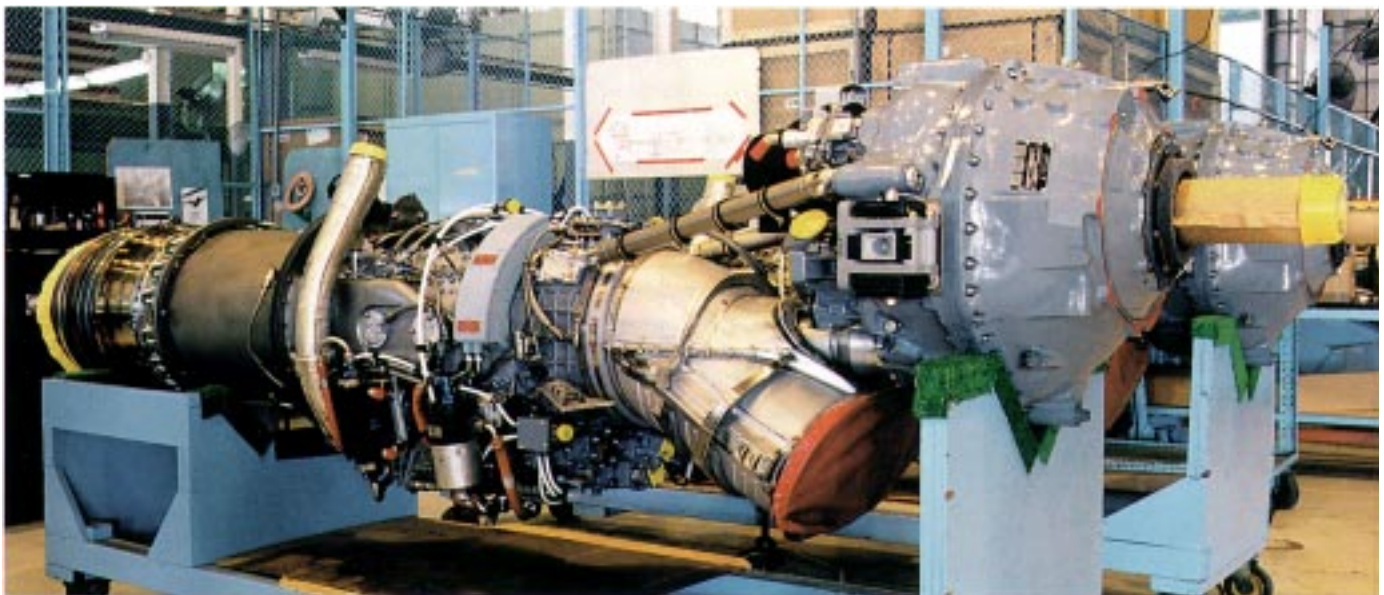

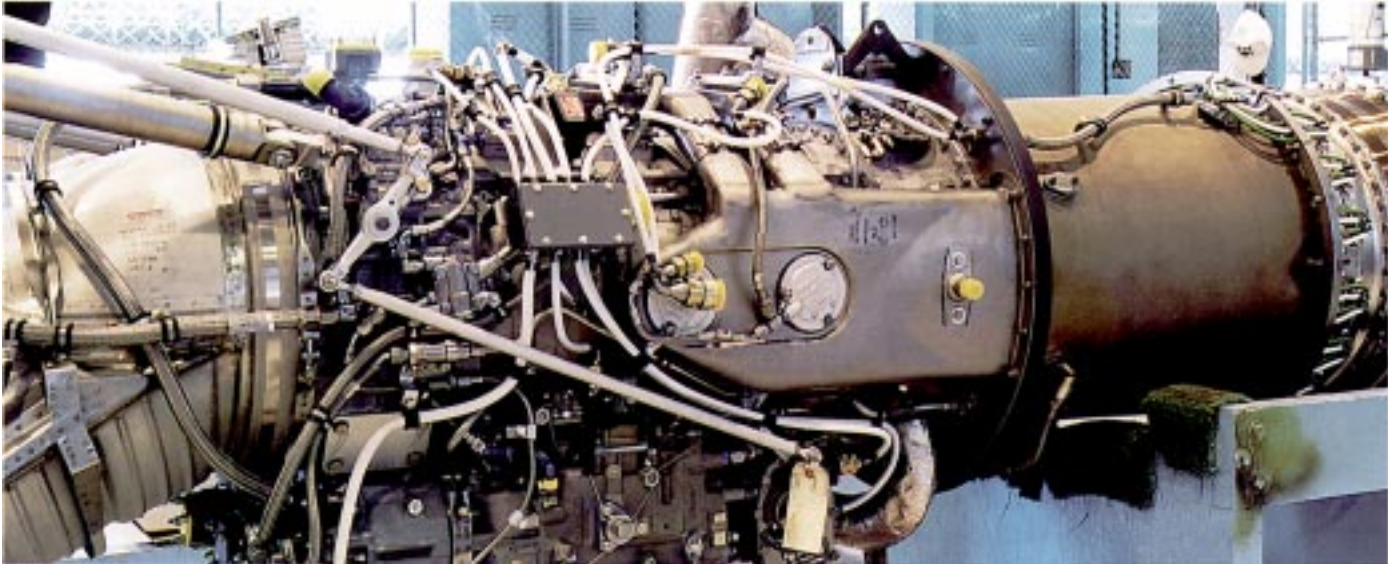

### Teflon Hoses for the T56-15/16 and 501D22A Engines

Part Number	Description
6876645	Fuel, Pump Case Drain
6844814-041097	Fuel, Aneroid to Inlet Housing
6876646	Fuel, Pump to LP Filter
6876647	Fuel, LP Filter to Fuel Pump
23055606	Fuel, Pump to Enrichment
6876644	Fuel, Enrichment to Control
6876649	Fuel, Pump to Control
6877200	Fuel, TD Valve to Control
6876648	Fuel, TD Valve to Pump
6877201	Fuel, Control to TD Valve
6876079	Fuel, Valve to FF Transmitter
6876082	Fuel, FF Transmitter to Drip Valve
6876077	Manifold, Fuel, Left-Hand
6876078	Manifold, Fuel, Right-Hand
6846454-061140	Air, Filter to Speed Valve
6877245	Air, Speed Valve to Hose Tee
6844814-061114	Air, Compressor Bleed Valve
6847553-041132	Air, Compressor Bleed Valve
6844335-069171	Air, Compressor Bleed Valve
6844747-041085	Air, Compressor Bleed Valve
6844814-061137	Air, Compressor Bleed Valve
6844815-041114	Air, Compressor Bleed Valve
6844815-061126	Air, Compressor Bleed Valve
6844815-041122	Air, Compressor Bleed Valve
6844815-041066	Air, Compressor Bleed Valve
6844814-041246	Air, Compressor Bleed Valve
6851398	Oil, Scavenge Filter to Fuel Heater
6887773	Oil, Power Section to Scavenge Filter
6851396	Oil, Reduction Gear Box to Scavenge Filter
6844745-121360	Oil, Vent, Accessory Drive Housing to Engine Breather



## QEC Hoses

The following list of QEC hoses are Lockheed Martin furnished Teflon and elastomeric hoses. The Teflon

hoses have no time-change requirements and are changed on the basis of condition only. The elastomeric hoses, however, do have a shelf and service life and must be replaced on a time-change basis.

### Teflon Hoses for the L-100/C-130 QEC

Part Number	Description
124002-4CR-0183	Drain, Fuel Recycle1
124001-4CR-0142	Vent, Fuel Recycle1
124001-4RC-0240	Drain, Fuel Recycle1
124D002-6CR-0150	Fuel, Recycle1
124D012D020DC00	Fuel, Recycle1
755200-3 (LAC) or 106852-3	Starter, Pressure Sensing

1 C-130; L-100 aircraft only if the fuel drain recycling system is installed.

### Elastomeric Hoses for the L-100/C-130 QEC

Part Number	Description
755124-1	Oil, Return to Oil Cooler
131040-24-0166	Alternate
S36B90082-0166	Alternate
156780-24D-0166	Alternate
755204-2	Oil, Reduction Gearbox Inlet
624166-N-0167	Alternate
156704-20D-0167	Alternate
131033-20D-0167	Alternate
S36B90083-0167	Alternate

*(Continued on the next page.)*



## Elastomeric Hoses for the L-100/C-130 QEC *(contd)*

Part Number	Description
755210-3	Oil, Gearbox Pressure
624162-4-0210	Alternate
156701-4S-0210	Alternate
131030-4-0210	Alternate
S36B90084-0210	Alternate
755211-2	Oil, Power Section Pressure
624162-4-0200	Alternate
156701-4S-0200	Alternate
131030-4-0200	Alternate
S36B90085-0200	Alternate
755235-3	Oil, Power Section Inlet
090-624176M0324	Alternate
156716H0324D90	Alternate
131037-16D-0324-90	Alternate
S36B90087-0324	Alternate
755238-1	Oil Cooler Outlet
131038-24D-0325	Alternate
156715K0325D270	Alternate
270-624189P0325	Alternate
S36B90136-0325	Alternate
755125-1	Fuel, Heater Strainer (Fuel In)
111271-16D-0256	Alternate
755227-1	Fuel, Power Section (Fuel In)
090-624168-M-0250	Alternate
S36B90110-0250	Alternate
131034-16D-0250-90	Alternate
156705H0250D90	Alternate
601000-4-0140	Drain, Aneroid
601001-12D-0274	Oil, Tank Drain
601002-4-0070	Fuel, Fuel Shaft Seal, Drain
601002-4-0101	Fuel, Drip Valve, Drain (C-130 only)
601002-4-0106	Fuel, Motor Cavity, Drain
601002-6D-0154	Oil, Scupper and Sump Oil Tank, Drain
601051-20D	Air, Power Section, Breather (C-130 only)
601051-20D-0204	Air, Power Section, Breather (L-100 only)
755129-1	Fuel, Burner Fuel, Drain (C-130 only)
AT1532	Alternate
755241-3	Oil, Oil Tank Scupper, Drain
131039-6D-0323-32	Alternate
156717D0323D32	Alternate
032-601721H0323	Alternate
S36B90089-0323	Alternate
MS28741-4-0110	Oil, Hydraulic Pump (Drain)
755224-3	Oil, Hydraulic Pump (Suction)
755208-1	Oil, Tank Return
624162-24D-0182	Alternate
131030-24D-0182	Alternate
156701-24D-0182	Alternate
S36B90081-0182	Alternate

*(Continued on page 11.)*



*INSIDE  
THE  
C-130J*

ROYAL AUSTRALIAN AIR FORCE

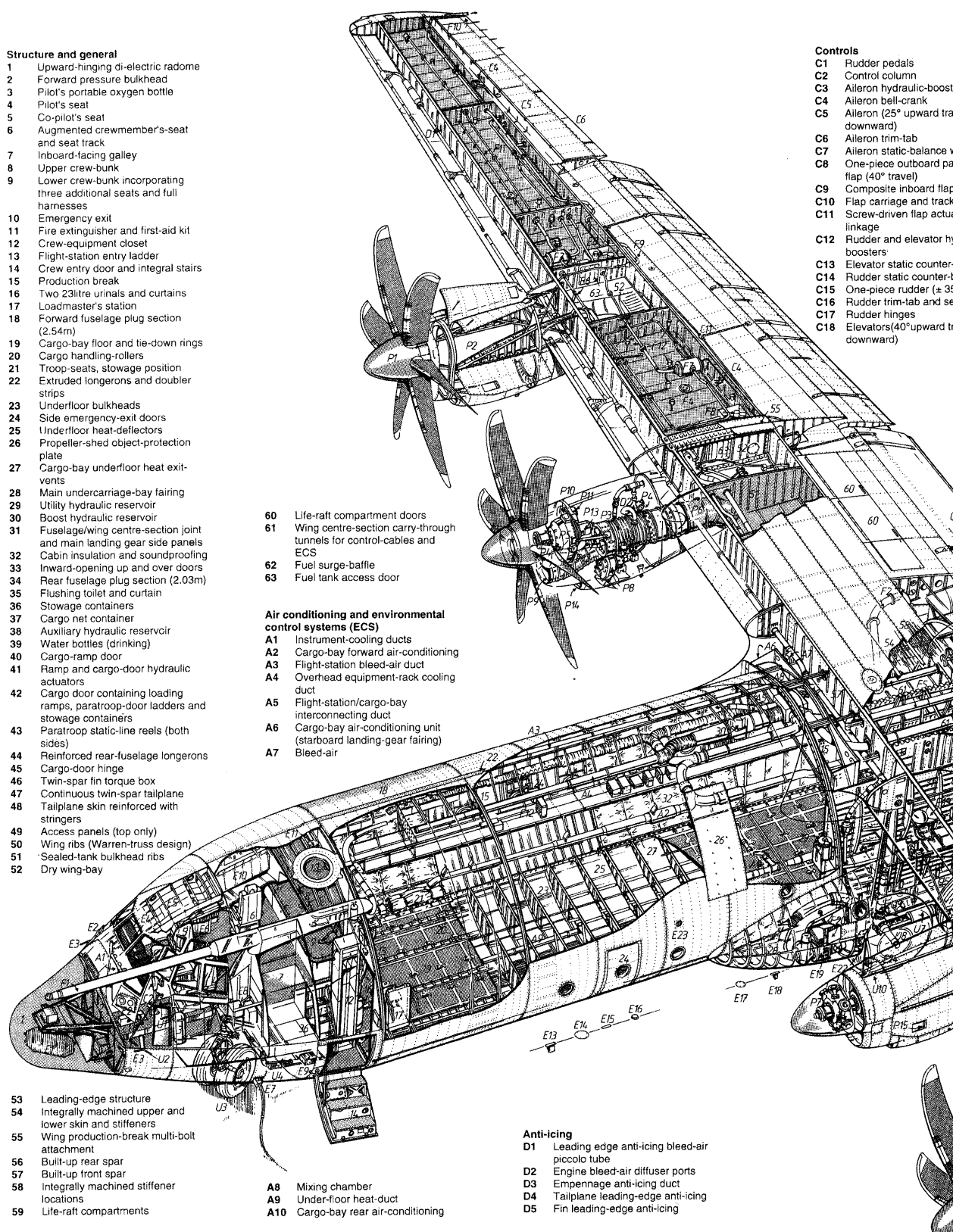

**Structure and general**

- 1 Upward-hinging di-electric radome
- 2 Forward pressure bulkhead
- 3 Pilot's portable oxygen bottle
- 4 Pilot's seat
- 5 Co-pilot's seat
- 6 Augmented crewmember's-seat and seat track
- 7 Inboard-facing galley
- 8 Upper crew-bunk
- 9 Lower crew-bunk incorporating three additional seats and full harnesses
- 10 Emergency exit
- 11 Fire extinguisher and first-aid kit
- 12 Crew-equipment closet
- 13 Flight-station entry ladder
- 14 Crew entry door and integral stairs
- 15 Production break
- 16 Two 23litre urinals and curtains
- 17 Loadmaster's station
- 18 Forward fuselage plug section (2.54m)
- 19 Cargo-bay floor and tie-down rings
- 20 Cargo handling-rollers
- 21 Troop-seats, stowage position
- 22 Extruded longerons and doubler strips
- 23 Underfloor bulkheads
- 24 Side emergency-exit doors
- 25 Underfloor heat-deflectors
- 26 Propeller-shed object-protection plate
- 27 Cargo-bay underfloor heat exit-vents
- 28 Main undercarriage-bay fairing
- 29 Utility hydraulic reservoir
- 30 Boost hydraulic reservoir
- 31 Fuselage/wing centre-section joint and main landing gear side panels
- 32 Cabin insulation and soundproofing
- 33 Inward-opening up and over doors
- 34 Rear fuselage plug section (2.03m)
- 35 Flushing toilet and curtain
- 36 Stowage containers
- 37 Cargo net container
- 38 Auxiliary hydraulic reservoir
- 39 Water bottles (drinking)
- 40 Cargo-ramp door
- 41 Ramp and cargo-door hydraulic actuators
- 42 Cargo door containing loading ramps, paratroop-door ladders and stowage containers
- 43 Paratroop static-line reels (both sides)
- 44 Reinforced rear-fuselage longerons
- 45 Cargo-door hinge
- 46 Twin-spar fin torque box
- 47 Continuous twin-spar tailplane
- 48 Tailplane skin reinforced with stringers
- 49 Access panels (top only)
- 50 Wing ribs (Warren-truss design)
- 51 Sealed-tank bulkhead ribs
- 52 Dry wing-bay

- 60 Life-raft compartment doors
- 61 Wing centre-section carry-through tunnels for control-cables and ECS
- 62 Fuel surge-baffle
- 63 Fuel tank access door

**Air conditioning and environmental control systems (ECS)**

- A1 Instrument-cooling ducts
- A2 Cargo-bay forward air-conditioning
- A3 Flight-station bleed-air duct
- A4 Overhead equipment-rack cooling duct
- A5 Flight-station/cargo-bay interconnecting duct
- A6 Cargo-bay air-conditioning unit (starboard landing-gear fairing)
- A7 Bleed-air

- 53 Leading-edge structure
- 54 Integrally machined upper and lower skin and stiffeners
- 55 Wing production-break multi-bolt attachment
- 56 Built-up rear spar
- 57 Built-up front spar
- 58 Integrally machined stiffener locations
- 59 Life-raft compartments

- A8 Mixing chamber
- A9 Under-floor heat-duct
- A10 Cargo-bay rear air-conditioning

**Anti-icing**

- D1 Leading edge anti-icing bleed-air piccolo tube
- D2 Engine bleed-air diffuser ports
- D3 Empennage anti-icing duct
- D4 Tailplane leading-edge anti-icing
- D5 Fin leading-edge anti-icing

**Controls**

- C1 Rudder pedals
- C2 Control column
- C3 Aileron hydraulic-boosters
- C4 Aileron bell-crank
- C5 Aileron (25° upward travel downward)
- C6 Aileron trim-tab
- C7 Aileron static-balance valve
- C8 One-piece outboard panel flap (40° travel)
- C9 Composite inboard flap
- C10 Flap carriage and track
- C11 Screw-driven flap actuator linkage
- C12 Rudder and elevator hydraulic boosters
- C13 Elevator static counter-balance
- C14 Rudder static counter-balance
- C15 One-piece rudder (+35° downward)
- C16 Rudder trim-tab and seal
- C17 Rudder hinges
- C18 Elevators(40° upward travel downward)

# LOCKHEED MARTIN C-130J

(C-130J-30 shown.)



- C19 Elevator hinges
- C20 Elevator trim tab

**Electrics and electronics**

- E1 Westinghouse MODAR 4000 colour weather/navigation radar
- E2 AAR-47 forward missile-warning sensors and ALR-56M RDR warning receivers
- E3 Electrically heated pitot tubes
- E4 Instrument panels
- E5 Overhead electrical panel
- E6 Pilot's head-up display unit
- E7 External-power receptacle point
- E8 Avionics rack
- E9 ALE-47 flare dispensers
- E10 Augmented crewmember workstation
- E11 TCAS II antenna
- E12 Overhead electronic-equipment rack
- E13 VHF antenna 1 and 2
- E14 Doppler altimeter
- E15 Radar altimeter
- E16 TCAS antenna
- E17 IFF antenna
- E18 UHF antenna
- E19 GTCP85-185L[A] auxiliary power unit
- E20 APU intake
- E21 APU exhaust
- E22 Air-conditioning ground-connector
- E23 Leading-edge observation light
- E24 Landing light
- E25 ALE-47 chaff/flare dispensers

- E26 ALQ-157 infra-red countermeasures
- E27 UHF antenna
- E28 VHF antenna
- E29 HF antenna
- E30 UHF navigation antenna
- E31 Upper rotating beacon
- E32 Static-discharge wicks
- E33 AAR-47 missile-warning sensors
- E34 ALR-56M RDR warning receiver
- E35 ALE-47 chaff dispensers

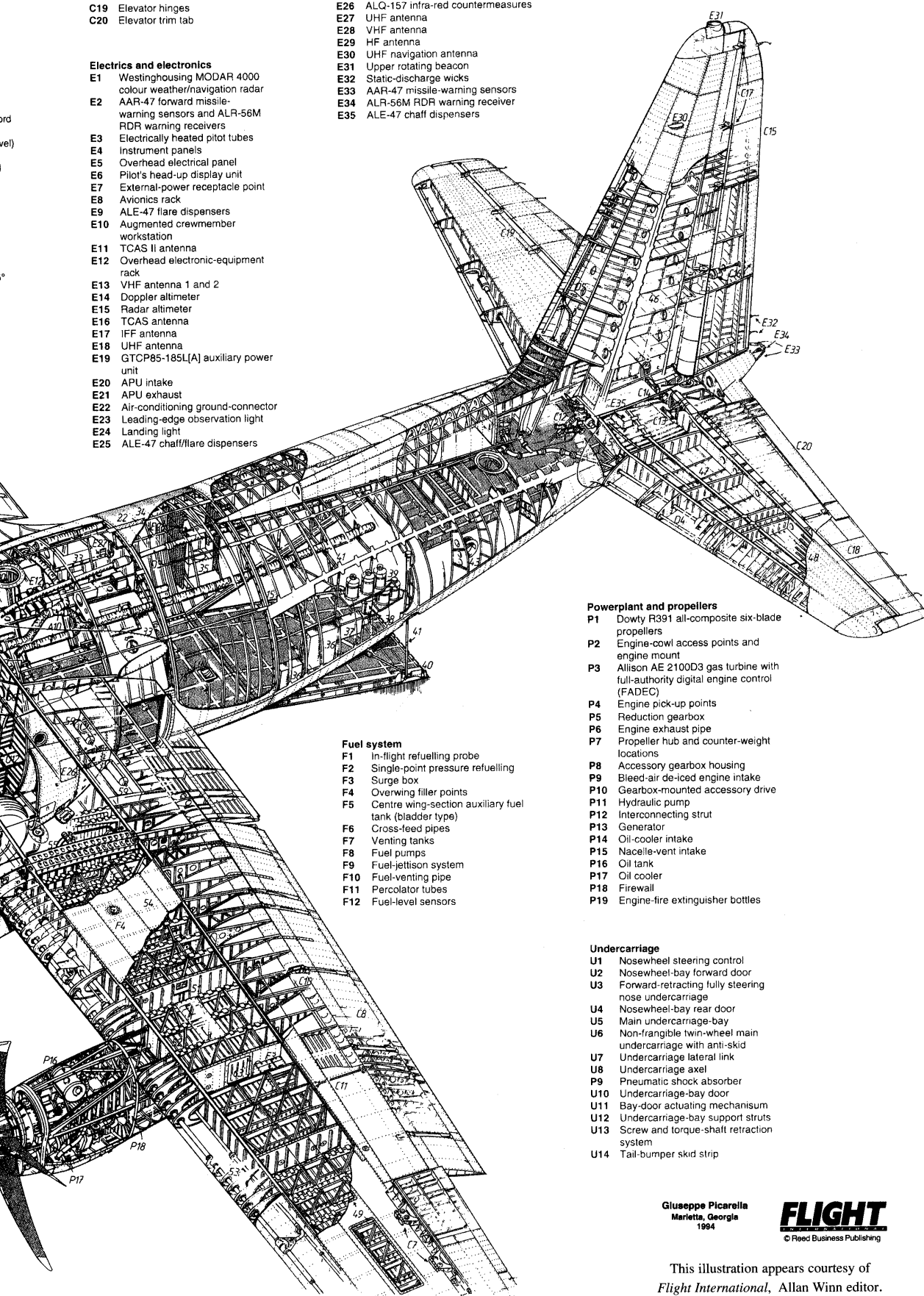

**Fuel system**

- F1 In-flight refuelling probe
- F2 Single-point pressure refuelling
- F3 Surge box
- F4 Overwing filler points
- F5 Centre wing-section auxiliary fuel tank (bladder type)
- F6 Cross-feed pipes
- F7 Venting tanks
- F8 Fuel pumps
- F9 Fuel-jettison system
- F10 Fuel-venting pipe
- F11 Percolator tubes
- F12 Fuel-level sensors

**Powerplant and propellers**

- P1 Dowty R391 all-composite six-blade propellers
- P2 Engine-cowl access points and engine mount
- P3 Allison AE 2100D3 gas turbine with full-authority digital engine control (FADEC)
- P4 Engine pick-up points
- P5 Reduction gearbox
- P6 Engine exhaust pipe
- P7 Propeller hub and counter-weight locations
- P8 Accessory gearbox housing
- P9 Bleed-air de-iced engine intake
- P10 Gearbox-mounted accessory drive
- P11 Hydraulic pump
- P12 Interconnecting strut
- P13 Generator
- P14 Oil-cooler intake
- P15 Nacelle-vent intake
- P16 Oil tank
- P17 Oil cooler
- P18 Firewall
- P19 Engine-fire extinguisher bottles

**Undercarriage**

- U1 Nosewheel steering control
- U2 Nosewheel-bay forward door
- U3 Forward-retracting fully steering nose undercarriage
- U4 Nosewheel-bay rear door
- U5 Main undercarriage-bay
- U6 Non-frangible twin-wheel main undercarriage with anti-skid
- U7 Undercarriage lateral link
- U8 Undercarriage axle
- U9 Pneumatic shock absorber
- U10 Undercarriage-bay door
- U11 Bay-door actuating mechanism
- U12 Undercarriage-bay support struts
- U13 Screw and torque-shaft retraction system
- U14 Tail-bumper skid strip

Giuseppe Picarella  
Marietta, Georgia  
1994

**FLIGHT**  
© Reed Business Publishing

This illustration appears courtesy of  
*Flight International*, Allan Winn editor.



Two C-130J-30s and a C-130J (center) in formation flight over the Georgia countryside.

## C-130J QUICK FACTS AND FIGURES

		C-130J		C-130J-30	
		International	USAF	International	USAF
Operating Weight Empty	lbs	75,562	80,619	79,291	84,348
Max. Gross Payload (2.5g)	lbs	41,790*	39,311*	38,061*	35,582*
Max. Takeoff Weight (2.5g)	lbs	164,000	164,000	164,000	164,000
Max. Payload Range	nm	3,150	2,825	3,200	3,000
Max. Effort T/O Roll (ISA)	ft	2,086	2,086	2,602	2,602
Max. Effort T/O Distance (50 ft)	ft	3,322	3,322	3,904	3,904
Landing Distance	ft	2,470	2,470	2,470	2,470
Long-Range Cruise Speed	ktas	312	312	312	312
High-Speed Cruise Speed	ktas	335	335	335	335
Initial Cruise Altitude	ft	28,000	28,000	28,000	28,000
Time to Climb to 20,000ft	min	14	14	14	14

Note: All data given in the table above represent interim values, subject to change

\* Increased payload studies are underway.

## Elastomeric Hoses for the L-100/C-130 QEC (contd)

Part Number	Description
111351-16-0240	Alternate
755226-1	Pump, Hydraulic Drain
111300-6-0300	Alternate
755232-1	Pump, Hydraulic Pressure
149-50103-0460	Alternate
755239-1	Pump, Hydraulic Pressure
149-5018-0256	Alternate
755210-5	Oil, Gearbox Pressure (L-100 only)
131030-4-0130	Alternate (L-100 only)
156701-4S-0130	Alternate (L-100 only)
624162-4-0130	Alternate (L-100 only)
S36B90084-0130	Alternate (L-100 only)
755211-3	Oil, Power Section Pressure (L-100 only)
131030-4-0340	Alternate (L-100 only)
156701-4S-0340	Alternate (L-100 only)
624162-4-0340	Alternate (L-100 only)
S36B90085-0340	Alternate (L-100 only)

### Aft Nacelle

The Teflon and elastomeric hoses listed below are for the aft nacelle. They are all Lockheed Martin-furnished equipment.

In this case also, the Teflon hoses are changed on the basis of condition only. The elastomeric hoses have a specific shelf and service life, and must be replaced on a time-change basis.

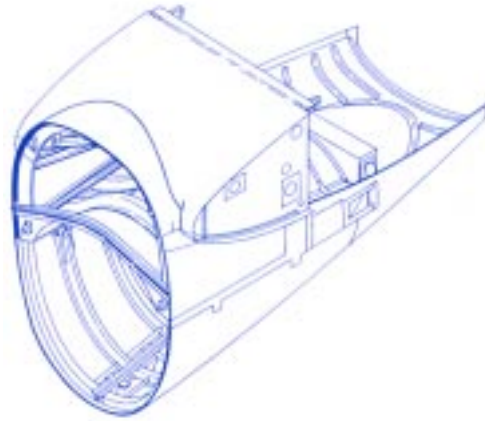

### Teflon Hoses for the L-100 Aft Nacelle

Part Number	Description
TR736CC41-10-0282	Pump, Hydraulic Pressure
000AE9010T-0282	Alternate
66060610-0282S	Alternate
AE1000429-J0282	Alternate
AE2460011-J0282	Alternate

### Teflon Hoses for the C-130 Aft Nacelle

Part Number	Description
AS621-10-0282	Hydraulic Pump Pressure



## Elastomeric Hoses for the L-100/C-130 Aft Nacelle

Part Number	Description
MS28741-16-0310	Fuel,
ER28741-6-0292	Oil, Hydraulic Pump Case Drain
ER28741-16-0280	Oil, Hydraulic Suction Pump
755063-3	Extinguisher, Fire, #4 Engine (LAC PN)
206-3375-3	Alternate
AT1145	Alternate
353-100-00-18	Alternate
755062-7	Extinguisher, Fire, #1 & #4 Engines (LAC PN)
206-3340-7	Alternate
AT1127-7	Alternate
353-100-0040-103	Alternate
755062-g	Extinguisher, Fire, #2 & #3 Engines (LAC PN)
206-3340-g	Alternate
AT1227-9	Alternate
353-100-0040-104	Alternate

Remember that there are differing time change requirements for different operators, depending upon the maintenance program being used.

For example, the FAA requires that elastomeric hoses on commercial aircraft be replaced after 5 years in service. In the case of the U. S. Air Force, T.O. 1C-130(A)-6 also requires that elastomeric hoses be replaced after 5 years in use. An additional stipulation,

however, is that elastomeric hoses be replaced anytime the engine is removed from the QEC close to the 5-year replacement interval.

It should also be noted that the USAF has changed some QEC elastomeric hoses to Teflon. Since Lockheed Martin engineering has not yet approved these replacements, no part numbers are available for them.



by M. Paul Tengzelius  
Training Specialist  
Customer Training Systems Department  
Lockheed Martin Aeronautical Systems

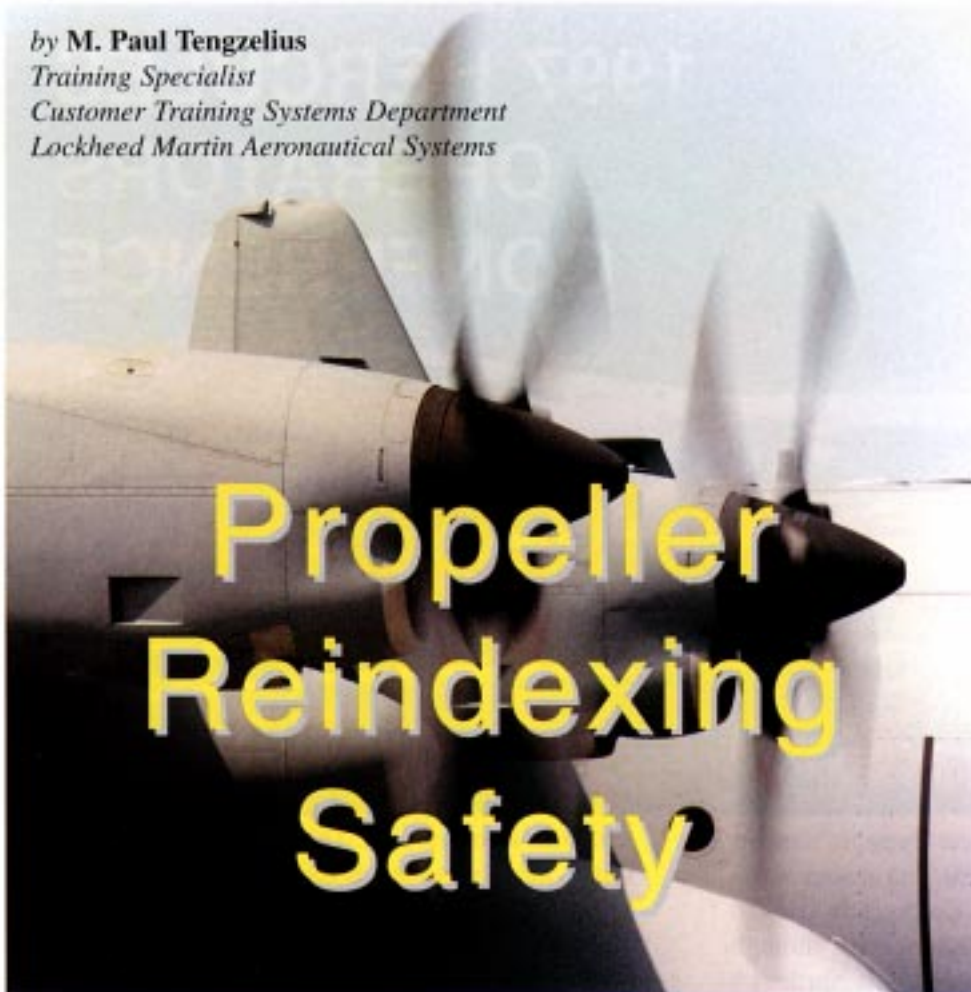

# Propeller Reindexing Safety

Propeller reindexing is normally accomplished during flight. The reason for this is the relative stability of propeller operation under flight conditions. But there are times when it may not be possible to put off reindexing the propellers until the next flight. T. O. 1C-130H-1 puts it this way:

Since propeller operation is more stable in flight than on the ground, reindexing, when necessary, should be performed during stable flight conditions. However, if normal governing is out of limits, or fluctuating on the ground, this procedure should be performed before considering the condition discrepant.

In situations like this, when a possible problem exists, propeller reindexing must be accomplished on the ground. The present ground propeller reindexing procedures described in the Lockheed Martin maintenance manuals state that in order to accomplish a good propeller reindexing, it is necessary to advance all four throttles beyond the temperature datum system crossover point and establish that all engines are devel-

oping a minimum of 8000 inch-pounds of torque.

This approach is ordinarily safe enough when the outside air temperature is at or above standard-day conditions. In cold weather, however, and especially in icy or snowy conditions, there is a significant element of risk involved.

On the T56-A-15 engine, the torque produced in cold weather can be as high as 14,000 to 16,000 inch-pounds at crossover (820°C TIT). At this high power setting, it is very difficult to prevent the aircraft from sliding on an icy or snow-covered surface. Even on a dry surface with chocks properly installed, the airplane will bounce excessively and threaten to jump the chocks.

Fortunately, it is unnecessary to employ such high power settings to reindex the propeller.

Propeller operation is based on maintaining approximately 100% rpm when in the governing range. An analysis of the operation of the temperature datum and propeller systems will show that the crossover point has no effect on propeller operation, except when the throttle is actually being moved through it. The change in engine power at crossover can cause the propeller to respond in the form of an adjustment in the blade angle.

If the throttle is advanced far enough for the engine to develop 8000 to 10,000 inch-pounds of torque—even if this is still below crossover—the propeller will be well within the controlling range. At this point, an adequate and complete reindexing of the propeller system can be accomplished without exposing the aircraft or crew to the hazards of jumping the chocks or sliding across an icy or snow-covered surface.

Keep in mind that while avoiding high power settings, the torque at which crossover occurs should still be observed whenever possible to ensure that it does not occur within the torque range being used for reindexing.





**L**ockheed Martin Aeronautical Systems Support Company (LMASSC) is pleased to announce the ninth Hercules Operators Conference (HOC). The conference will be held October 13 through October 17 of 1997 at the Atlanta Marriott Northwest Hotel, which is located near our facilities in Smyrna, Georgia. The theme for this year's conference is "Hercules – Meeting the Challenge."

As in the case of last year's HOC, we have mailed a copy of the preliminary agenda to everyone who has indicated an intention to attend. This helps operators and other visitors make their plans well in advance of the conference opening date.

We want to emphasize that the HOC agenda is largely determined by the input from the conference attendees. The subjects to be included will be based on the ideas, inquiries, and contributions of the conference participants. Without your timely support, we must substitute available material to complete the agenda. The inputs sent in to us do, therefore, make a big difference, and we strongly encourage attendee participation.

The final agenda will be completed in advance to allow copies to be presented to each attendee at registration. We expect to expand the usual working groups this year to include, as a minimum, a new one dealing

with the avionics area. Other subjects may also be added, based upon inputs received during the next few months. It is our intent to make this conference the best one ever, informative and interesting for everyone. We are soliciting input and presentations from all attendees, including those who may only have a few aircraft.

Most presentations will be scheduled for approximately 20 minutes of conference time. However, we encourage our attendees to make a presentation even if it lasts for only 5 minutes, or even less. We all can benefit from experiences of other operators and we encourage all to present topics and participate wholeheartedly. The input may be just a brief comment or question for the group, but it will be no less welcome, even if brief.

If you have not received HOC registration materials and would like to attend the 1997 Hercules Operators Conference, clip out or photocopy the form on page 15, fill it out, and fax it to 770-431-6556. You may also mail the form to following address:

**LMASSC  
P.O. Box 121  
Marietta, GA 30061**

We look forward to hearing from each of you at your earliest convenience.





# 1997 HERCULES OPERATORS CONFERENCE

## Preregistration Form

Phone: 770-431-6565

FAX: 770-431-6556

OPERATOR IDENTITY: (Location)

Phone:

Name/Title/Organization:

Address:

Fax:

GENERAL DESCRIPTION OF YOUR ORGANIZATION:

HOC REPRESENTATIVE:

ATTENDEES:

PRESENTERS:

TOPICS:

ITEMS OF INTEREST FOR CONFERENCE:

AIRCRAFT FLIGHT HOURS – BY LAC SERIAL NUMBERS:

CONFERENCE FEE: (Nonrefundable, per person, payable in US dollars at registration.)

International operators – \$100

U.S. government (military and civilian) – \$100

Vendors, contractors, and service centers – \$300

*Lockheed Martin Aeronautical Systems Support Company*

Airlift Field Service Department  
2251 Lake Park Drive  
Smyrna, GA 30080-7606

