



# Service News

Editor

Charles I. Gale

Vol. 24, No. 2, October–December 1997

**CONTENTS**

- 2 Focal Point**  
F. D. "Don" Greene, Manager  
Airlift Field Service Department
- 3 New Emergency Exit Lights**  
The C-130's new emergency lighting  
system provides more reliable illumina-  
tion when you need it most.
- 9 Emergency Exit Light Battery Charger**  
This computer-controlled discharger-  
charger unit helps ensure maximum  
performance and long service life from  
emergency exit light nicads.
- 12 APU Access Door Update**  
Water accumulation between the outer  
skin and interior stiffener can be cured  
by a simple modification.
- 14 On Board the C-130J**  
More power, longer range, and  
improved high-altitude operation are  
just a few of the advances offered by  
the C-130J.

**Covers:** Rugged, versatile, and every  
inch a Hercules, the C-130J is the pre-  
mier airlifter for the 21st century.

Photographic support by John Rossino  
and Rita King.

Digital PrePress and Printing support by  
*Video & Publication Services, O/46-C4,*  
Lockheed Martin Missiles and Space  
Sunnyvale, CA (408)742-4870

## Focal Point

### Turning the Page

There is nothing in life as inevitable as change, and this applies to organizations just as it does to individuals. At the Airlift Field Service Department of Lockheed Martin Aeronautical Systems Support Company, recent milestones have included the retirement of C. R. "Charlie" Kelley, who was supervisor of our C-130/L-100 Support Section, and J. N. "Joe" Coker, who headed up our C-5 /C-141 Support Section. Both served with professionalism and distinction, and earned the enduring respect of their colleagues as well as Lockheed Martin customers throughout the world. We wish them the very best in their retirement years.



**Airlift Field Service Manager Don Greene, with Glenn Bender and Tom Zembik.**

It is never easy to replace seasoned professionals, but we are pleased to announce the appointment of two individuals ideally suited to lead these key organizations into the 21st century. T. J. "Tom" Zembik has been appointed to the position of C-130/L-100 Support Section Supervisor, which includes support of the new C-130J. Tom first joined Lockheed Martin as an aircraft mechanic over 20 years ago. Since then, he has held positions of increasing responsibility with Lockheed Martin at locations all over the world, including nearly 15 years as a Field Service Representative.

The responsibilities of the C-141/C-5 Support Section have been assigned to G. N. "Glenn" Bender. Glenn, who began his Lockheed Martin career as a C-5 Avionics Field Service Representative, has broad experience in all aspects of airlift maintenance, including the administrative and financial sides of the business.

As we welcome Tom and Glenn to their new posts, we are confident that our customers will continue to enjoy the expert, full-service professional support that has long been the hallmark of Lockheed Martin Field Service.

Sincerely,

F. D. "Don" Greene  
Manager, Airlift Field Service

LOCKHEED MARTIN AERONAUTICAL  
SYSTEMS SUPPORT COMPANY

J. L. GAFFNEY – PRESIDENT

FIELD  
SUPPORT

J. D. ADAMS

BUSINESS  
DEVELOPMENT

G. M. LOWE

*Service News* is published by Lockheed Martin Aeronautical Systems Support Company, a subsidiary of Lockheed Martin Corporation. The information contained in this issue is considered to be accurate and authoritative; it should not be assumed, however, that this material has received approval from any governmental agency or military service unless specifically noted. This publication is intended for planning purposes only, and must not be construed as authority for making changes on aircraft or equipment, or as superseding any established operational or maintenance procedures or policies.

Copyright 1997, Lockheed Martin Corporation. Written permission must be obtained from Lockheed Martin Aeronautical Systems Support Company before republishing any material in this periodical. Address all communications to Editor, *Service News*, Lockheed Martin Aeronautical Systems Support Company, 2251 Lake Park Drive, Smyrna, GA 30080-7605. Telephone 770-431-6544; Facsimile 770-431-6556. Internet e-mail may be sent to cigale@mar.lmco.com.



# New Emergency Exit Lights



by **Phillip J. Gammell**  
*Design Engineer, Specialist*  
*C-130H/C-130J Lighting Systems*  
*Lockheed Martin Aeronautical Systems*

**Better Light When You Need It Most**

The emergency exit lights (EELs) that are installed on Lockheed Martin C-130H aircraft serial number 5421 and up are of a more modern design than their predecessors, and offer a number of advantages that improve both their performance and maintainability. Now provided as standard equipment on all new-production C-130J Hercules aircraft, the improved units are manufactured by Soderberg Manufacturing Company of Walnut, California, and have been assigned PN S2320-101.

The new design incorporates many features that were lacking in the earlier lights, but the new units still retain a high degree of functional similarity with those of the older type. In both emergency lighting systems, arming power is supplied from the essential DC bus and disarming power is supplied from the battery bus. Also as in the older system, the new EELs can be disarmed by using the emergency exit light extinguish switch located on the exterior lighting control panel in the overhead console of the flight station.

## Solving EEL Problems

Although the old emergency lighting served adequately for many years, reports from the field showed that there were a number of continuing nuisance problems with the older units. This, together with the advent of improved technology, have combined to make an update of the system appropriate.

One of the problems with the older system is that the EELs are powered by ordinary D-cell flashlight batteries. This not only makes the individual EEL units heavy and relatively large in size, but subjects them to chemical leakage and corrosion if the batteries are left

**The new EELs are lightweight, compact, and designed for long, trouble-free service.**





Two small, rechargeable nicads in each unit (top) replace the four heavy, bulky D-cells that power the older EELs.

installed too long. The old EELs are also internally complex, containing inertia switches, latching relays, and arm/disarm/test switches. This not only increases the cost, but introduces other disadvantages as well. For example, if the arm/disarm/test switch on one of the units is left in the disarm position prior to flight, someone will have to climb a ladder to arm the light.

### In With the New

The improvements built into the new EEL design are intended to solve these kinds of problems and make the EELs more reliable and easier to maintain. One of

### Aircraft emergency exit light wiring.

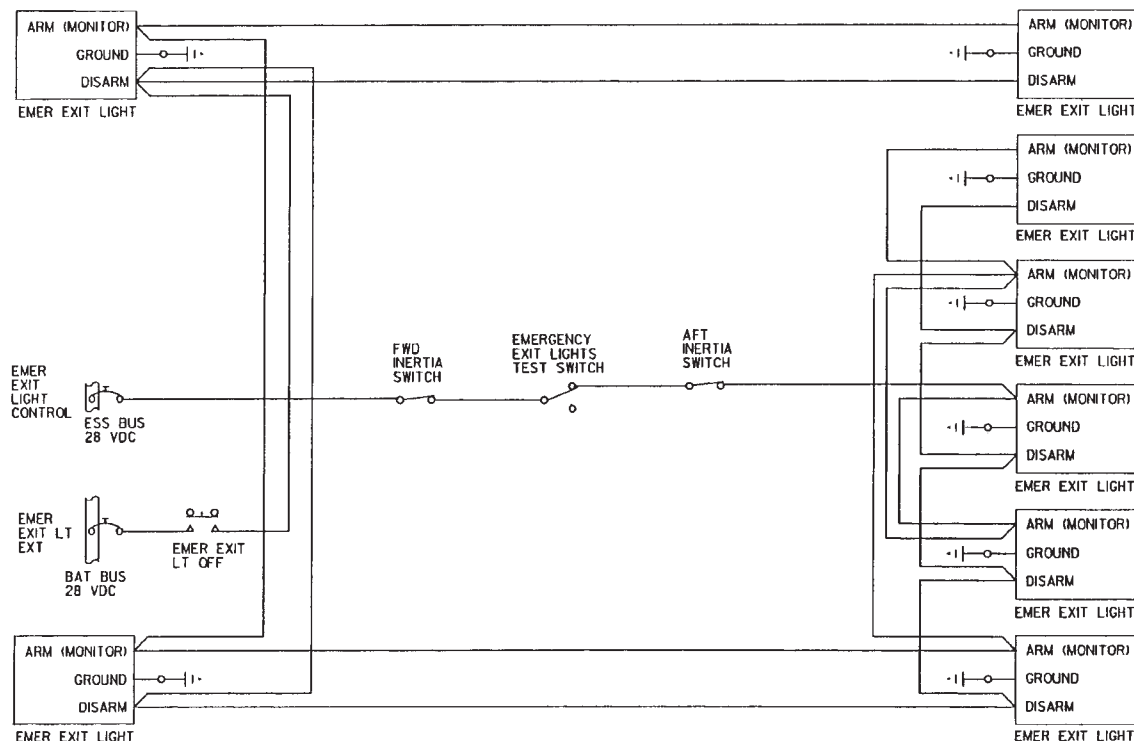

the new features is that the D-cell batteries used in the existing EELs have been eliminated and replaced with nickel-cadmium (nicad) batteries. Nicad batteries are rechargeable and, if handled correctly, have a long service life. A trickle charge is automatically applied to the nicads whenever the aircraft is powered. This helps keep the new batteries fully charged and ready for use.

Another change is that the new system removes the internal inertia switches from the individual units and transfers this function to two new inertia switches installed on the airframe. One is located forward, at FS 238; the other is aft, at FS 927. The flow of 28 VDC to the EELs may be interrupted by the activation of either of these inertia switches. When this occurs, all of the EEL units will illuminate.

The arm/disarm/test switches have also been eliminated from the individual EEL units in the new system. A test switch located outside of the EELs and mounted on the bulkhead at FS 241 serves not only to functionally test the entire EEL system, but also acts as an enable/disable switch.

### The New EEL Units

The new PN S2320-101 EEL consists of a mounting base and the EEL unit. The lens of the EEL lamp is dark green on aircraft that have Night Vision Imaging System (NVIS) equipment installed so that the EEL

system will not interfere with the NVIS in case a light unit is accidentally activated during flight.

Each EEL base is mounted to the aircraft using three fasteners, and is installed so that its lamp illuminates an exit. The base now utilizes plunger-type contacts, unlike earlier versions of this light, which had leaf-spring-type contacts. Experience has shown that the leaf-spring contacts eventually lose tension and become bent backwards. This results in poor electrical contact and causes the affected EEL unit to malfunction. Efforts to restore the electri-

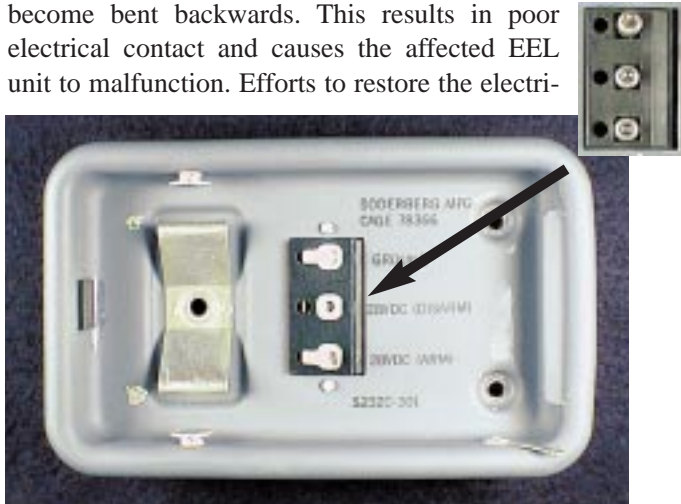

**The original leaf-type contactors on the light base have been replaced by rugged plunger-type contactors.**

cal connection by bending the contactors back upward may break them, as happened in the case of the center contactor in the illustration above.

The plunger-type contactors eliminate this problem by incorporating a small coil spring in the plunger assembly. This ensures that good physical contact is maintained between the base unit and the light unit at all times. The plungers use screw terminals on the back side of the light base to attach to the aircraft wiring.

### System Operation

There are eight EELs installed in all recently produced C-130 aircraft. Each EEL is mounted so that its light illuminates a normal or an emergency exit. The arm contact for all of the EELs is supplied with 28 VDC power from the essential DC bus. The power is first routed to the forward inertia switch located on the FS 241 bulkhead. From this point, it flows through the enable/disable-test switch, also mounted on the forward bulkhead, and then through the aft inertia switch installed below the aft emergency exit light. From there, power is applied to the arm contact of each of the EELs.

Each EEL unit has three contacts that mate to the aircraft wiring via the EEL base contactors. The three contacts are identified as ARM, DISARM, and GROUND by labels molded into the back of the base unit. As noted above, the arm contact receives 28 VDC power from the essential DC bus. This energizes a spring-loaded relay mounted on a circuit board inside the EEL and pulls a latching relay to the “arm” position. Applying 28 VDC to the disarm contact returns the latching relay to the disarm position. The ground contact is used to ground the EEL to the aircraft structure.

When the latching relay is in the arm position and the spring-loaded relay in the energized position, the nicad batteries are disconnected from the EEL lamp. Upon a loss of power to the arm contact, the spring-loaded relay deenergizes. This connects the nicad batteries to the lamp, which then illuminates.

As long as 28 VDC is applied to the arm contacts of the EELs, all of the EELs will be armed. This means that they are ready for use, but their lamps remain extinguished. The lamps will not come on until something happens to remove 28 VDC from the arm contacts. When this occurs, the circuit connecting the lamps in EEL units to their batteries will close, and their lamps will illuminate.

### Lighting the Lamps

The 28 VDC power that arms the EELs can be lost in several ways. One is the loss of power to the essential DC bus. This occurs every time power is removed from the aircraft, and the flight station crew must remember to disarm the EEL unit circuitry by operating the overhead emergency exit light switch in the flight station or the lights will illuminate as soon as aircraft power is shut down.

**Each EEL unit has three contact points designed to mate with the plunger contactors on the light base.**





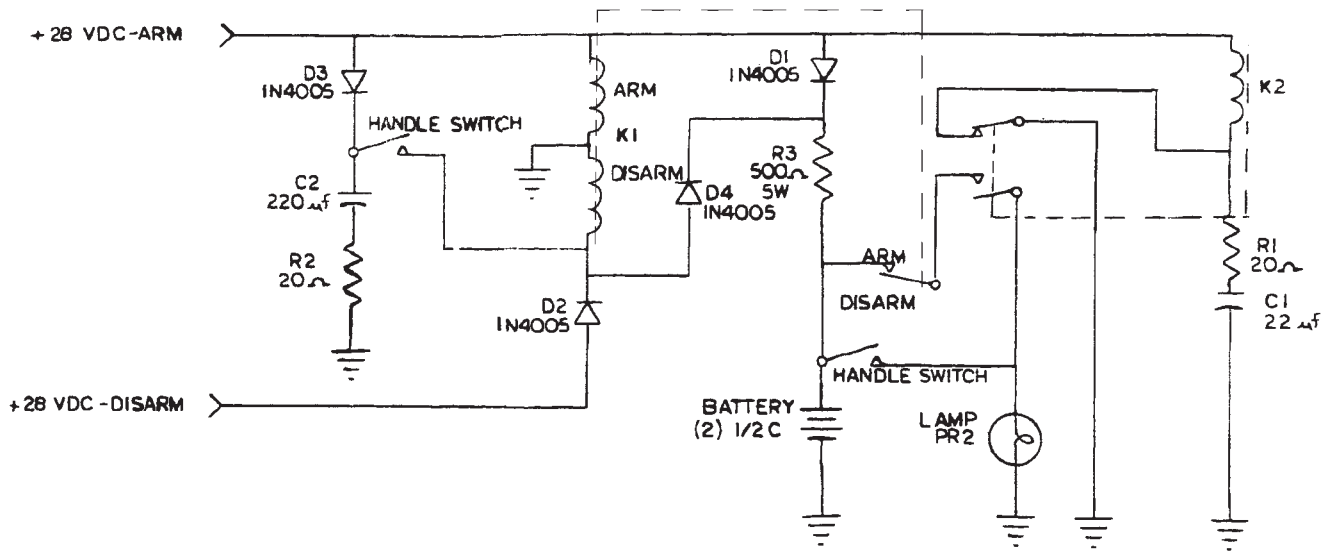

Electrical schematic, PN S23200-101 Emergency Exit Light, shown energized (+28 VDC) and armed.

Another way to remove 28 VDC power from the arm contacts of the EEL units is to place the enable/disable-test switch at FS 241 in the disable-test position. This is a two-position switch used both as a master enable and disable-test switch. If the switch is placed in the disable-test position with aircraft power applied, the EELs will activate and their lamps will illuminate. When the switch is returned to the enable position, the EELs will rearm, thereby extinguishing the lamps.

The third way to remove arming power from the EELs and cause the lamps to illuminate is for either of the system's inertial switches to be activated by a forward deceleration of 2Gs or greater. If the EELs are activated this way, the inertia switches may be reset by pressing the reset button on the forward side of each inertia switch.

Lastly, an EEL is activated when its red handle is pulled down and the EEL is removed from its base. This interrupts the 28 VDC circuit to the arm contacts and also closes an internal switch, allowing the lamp to illuminate. The unit can be deactivated by returning the red handle back to the up position, which opens the internal switch and turns off the lamp.

### Disarming the EELs

Disarming an EEL ensures that it will not illuminate automatically when, for whatever reason, power is removed from the arm contact. There are two ways to

disarm an EEL once it has been armed. The first is to apply 28 VDC to the disarm contact.

The disarm contact of each of the EELs is wired to the emergency light extinguish switch located on the flight station exterior lighting control panel. This switch is connected to the "hot" battery bus, and has 28 VDC available to it as long as the main aircraft battery is connected. When the switch is operated with aircraft power shut down, 18-24 VDC is applied to the disarm contact of all the EELs, driving the latching relay inside the EEL to the disarm position.

Battery voltage is not critical in this application. It can be as low as 12 VDC and the EELs will still disarm properly. If the aircraft battery is to be disconnected for

The principal internal components of the unit include a PR-2 lamp, electrical circuit board, and nicad batteries.

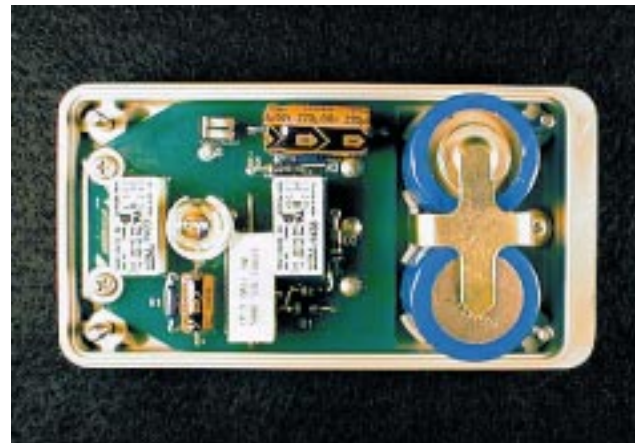

any reason, it is important to ensure that the emergency exit light extinguish switch has been used and the enable/disable-test switch placed in the disable-test position. This prevents the EELs from being activated under circumstances where 28 VDC arming power is not available and it will not be easy to deactivate them.

The second way to disarm the EEL is to remove the EEL from its mounting base by pulling the red handle down. Doing so discharges a capacitor inside the light to disarm the coil of the latching relay and breaks the connection between the nicad batteries and the main lamp.

Of course, if the handle is pulled down far enough after removing the EEL from its base, the lamp will illuminate. This is because further movement of the handle closes a mechanical switch between the nicad batteries and the lamp. This switches on the light and allows the EEL to be used as a portable source of illumination. Returning the handle to the up position breaks the connection and switches the EEL off.

### Batteries

A properly charged EEL should continue to provide illumination for a minimum of 30 minutes when the lamp is turned on. Some have even lasted as long as 1.5 hours. On the other hand, improperly charged EELs may last as little as 1 second, even after a full charge cycle. A light that illuminates only briefly demonstrates the *memory effect* in nicad batteries.

Even though a nicad battery cannot have a true memory since it is not a computer chip, this term is used to describe an effect in which the nicad battery's power output is reduced to the point where the EEL is useless. The memory effect can develop over a period of time if, for example, the EELs are repeatedly activated for more than a few seconds during aircraft power shutdowns. Deep discharge of nicad batteries must also be avoided. They can even reverse polarity if left to discharge for extended periods.

If EELs are left on overnight, their nicads are likely to discharge well below 0.5 volt. This will cause a significant reduction in battery service life, even after just one occurrence. Multiple occurrences of this type of abuse will completely destroy nicad batteries. Although the damage is not physically evident from the outside, the length of time the nicad can illuminate the lamp may become negligible, or even nonexistent.



**Moving the handle to full down position switches on the EEL and allows it to be used as a portable light source. For this service, the EEL is usually carried “upside down.”**

The way to overcome the memory effect in nicad batteries is to properly discharge and then recharge them. This can best be accomplished by periodically placing the nicads in a special discharger/charger unit (DCU). This device automatically discharges the nicads to the proper voltage and then carefully recharges them to the proper level. For best results the nicads should be placed in the discharge/charge unit at least once every 90 days, or just before a critical mission in which a discharger/charger unit will not be available.

### Discharger/Charger Unit

The PN ES125122-1 Emergency Exit Light Battery Charger was designed and built by Lockheed Martin Aeronautical Systems Company. Its features are

described in detail in the following article. The DCU is computer-controlled and very carefully monitors the discharge and charge states. Power for the DCU is 28 VDC, supplied via a connector that will mate to the 28 VDC receptacle in the aircraft or 28 VDC available in any aircraft maintenance shop.

In order to use the DCU, both nicad batteries must be removed from the EEL unit by taking off its back cover, loosening the battery clip that holds the batteries, removing both nicads, and placing them both in one of the battery holders in the DCU. Note that the screws for fastening back of the EEL are captive screws, but the screw for the battery holder inside the EEL is small and not a captive screw. Be careful not to lose it when the nicads are removed.

The batteries should be removed and placed in the DCU in pairs. Make sure that the DCU power switch is in the OFF position prior to installation of the nicad batteries.

The DCU discharges the nicads only when the discharge button is pressed; otherwise, the DCU will start charging the nicads when power to the DCU is switched on without first discharging them. The DCU monitors the voltage across each pair of nicads (one EEL's worth) during both the discharge and charge cycles. The DCU places a resistor across the nicad pair to discharge the nicads until the voltage across the nicads drops below

approximately 1.0 VDC per cell. This helps prevent the development of the memory effect in the nicad cells.

The discharge cycle may take as long as 45 minutes for fully charged nicads, and as little as one second for batteries that are fully discharged. Once the discharge button is pressed, the discharge lamp flashes until the voltages drops to less than 1.0 VDC per cell. At that point, the lamp illuminates steadily and removes the discharger resistor from the circuit. If a problem with the nicads is detected at any point after the discharge switch is depressed, the DCU discharge lamp will extinguish and the operation will terminate. If this occurs, the nicad batteries are defective and should be replaced.

There are two important things to remember in connection with proper handling of the EEL batteries: The first is to extinguish the EELs immediately if they illuminate upon shutting off aircraft power or after disabling the system. They can be left connected to aircraft power to trickle-charge for extended periods without ill effect.

The second is to maintain them properly through periodic, carefully controlled discharge and recharge cycles, such as provided by the DCU. Paying attention to these two simple procedures will greatly increase the life of the nicads in your aircraft and help ensure that the EELs will prove a reliable source of lighting when you need it most. □

**The nicads should be removed from the EEL and recharged in pairs. Be sure to keep track of the small battery clip and its retaining screw and washer while the unit is disassembled.**

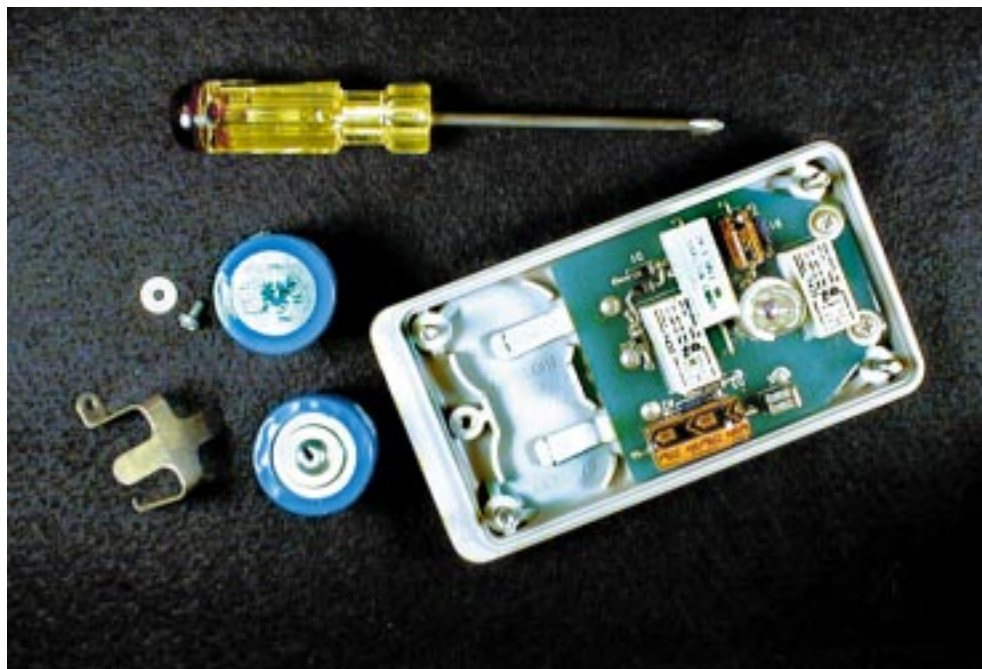



*Top Performance From EEL Nicads:*

# EMERGENCY EXIT LIGHT BATTERY CHARGER

by **Don Coia**, Staff Engineer  
*Electronic Support Equipment Department  
Lockheed Martin Aeronautical Systems*

The PN ES125122-1 Emergency Exit Light Battery Charger is designed to simultaneously test, discharge, and fast-charge up to eight pairs of the ½ C-cell batteries used in the aircraft emergency lights installed in current-production C-130Js. Similar batteries also equip the emergency exit lights in C-141 and C-5 aircraft. This new battery charger incorporates eight independent microprocessor-controlled charging circuits. The advanced design of the circuitry ensures



that operators will obtain top performance and maximum service life from EEL nicads.

### Purpose and Function

When nicad batteries are subjected to shallow charge-discharge cycles, they tend to display what is commonly referred to as “memory.” The symptoms include a temporary loss in the ability of the battery to accept a full charge, and a depression in voltage that they are able to produce. This voltage depression shortens the operating life of the emergency exit lights or other nicad-operated devices that may be powered by the affected cells.

To defeat this effect, the PN ES125122-1 Emergency Exit Light Battery Charger is designed to discharge a nicad battery fully, to below approximately 1 volt per cell, before any attempt is made to recharge it. After completion of the discharge cycle, the battery is then automatically recharged in a fast-charge cycle.

The battery charger has a built-in peak voltage-detect cutoff circuit designed to fast-charge the battery to 100% of its capacity and then terminate the charging process before any overcharge can occur. The charger may be used either at the airplane, or in any aircraft maintenance shop with a 28 VDC power source capable of supplying 3 amps.

### Capabilities

Nicad cells to be recharged are placed in the charger in pairs. After proper connections are made to 28 VDC power, the operator inserts the pair (or pairs) of batteries to be charged, turns the power switch on the charger to ON, and depresses the START/DISCHARGE button. The charger will automatically perform a diagnostic test, a complete discharge, and a fast-charge recharge of the installed batteries.

Any abnormal conditions will be reported to the operator through front-panel LEDs. A safety timer in

**The battery charger has the capacity to test, discharge, and recharge eight pairs of ½ C-cell nicads simultaneously.**

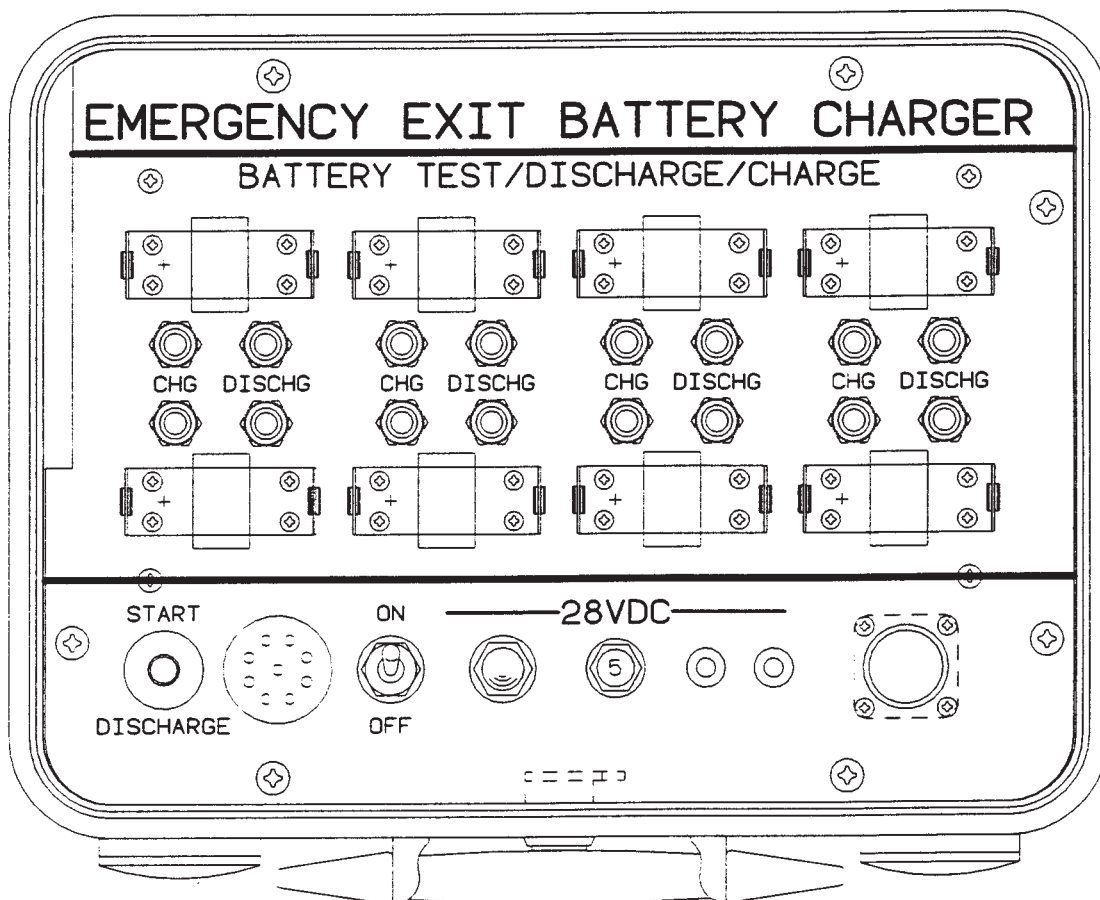

each microprocessor will stop the charging if the batteries being charged have still not reached their peak voltage after four hours have elapsed.

### Detail Description

The battery charger is housed in an aluminum case. The functions of the front panel items are as follows:

**Start/Discharge Switch** – Used for starting the battery discharge cycle. When the discharge is complete for any pair of batteries, the charge will automatically switch that pair of batteries to fast charge.

**ON/OFF Switch** – Used for switching 28 VDC to the charging circuits.

**Power-On Lamp** – Indicates that power is applied to the charger and switch S2 is in the ON position.

**Banana Jacks** – Provides an alternate method to input 28 VDC to the battery charger.

**DISCHG LEDs (8 each)** – These LEDs are amber in color and flash to indicate that the associated pair of batteries are discharging. The LEDs stop flashing and illuminate steadily when the discharge is complete.

**CHG LEDs (8 each)** – These LEDs are green in color and flash to indicate that its associated pair of batteries are charging. The LEDs stop flashing and illuminate steadily when the charging is complete.

Note that the LEDs will remain extinguished if an abnormal condition exists for its associated pair of batteries. If the CHG LEDs fail to illuminate at battery charger power-on, an open cell is indicated. Loss of the flashing CHG LED after discharge is complete (a steadily lit DISCHG LED) indicates a shorted cell.

### Dimensions, Weight, and Power Requirements

The dimensions and weight of the PN ES125122-1 battery charger (cover closed) are as follows:

- Height: 5 inches (12.7 cm)
- Width: 12 inches (30.5 cm)
- Depth: 9 inches (22.9 cm)
- Weight: Approximately 7 lbs (3.2 kg)
- Power required: 28 VDC, 3 amps

### List of Items Furnished

The PN ES125122-1 Emergency Exit Light Battery Charger is complete as shipped. No additional items are required to perform the nicad battery testing, discharge, or charge functions. In addition to the battery charger itself, the following items are provided with the set:

- ES121506-7 Cable Assy., 28 VDC Service Outlet
- ES121506-9 Cable Assy., Banana Plug
- ES121508-1 Operation/Maintenance Instructions

### Storage Data and Test Equipment

No special storage instructions are applicable to the battery charger, except that reasonable care should be exercised. Like all electronic test equipment, the unit should be stored in a dry, salt-free environment. The original shipping container (or equivalent) is suitable for any extended storage periods.

The battery charger is ruggedly built and designed with high-quality, stable components. No periodic servicing or calibration is required.

### Information

For procurement information, contact:

Lockheed Martin Aeronautical Systems  
Customer Supply Business Management Dept.  
D/65-11, Z/0577  
Marietta, GA 30063-0577  
Telephone: 770-494-4214  
Fax: 770-494-7657  
Telex: 542642

For technical information, contact::

Lockheed Martin Aeronautical Systems  
Electronic Support Equipment Eng. Dept.  
Attn: Don Coia  
D/73-F3, Z/0730  
Marietta. GA 30063-0730  
Telephone: 770-916-2631  
Fax: 770-916-2641

□



# APU ACCESS DOOR



# UPDATE

by **Tom Scoggins**, *Field Support Analyst*  
*Lockheed Martin Aeronautical Systems Support Company*  
and **Mike Smith**, *Principal Engineer, Design*  
*Lockheed Martin Aeronautical Systems*

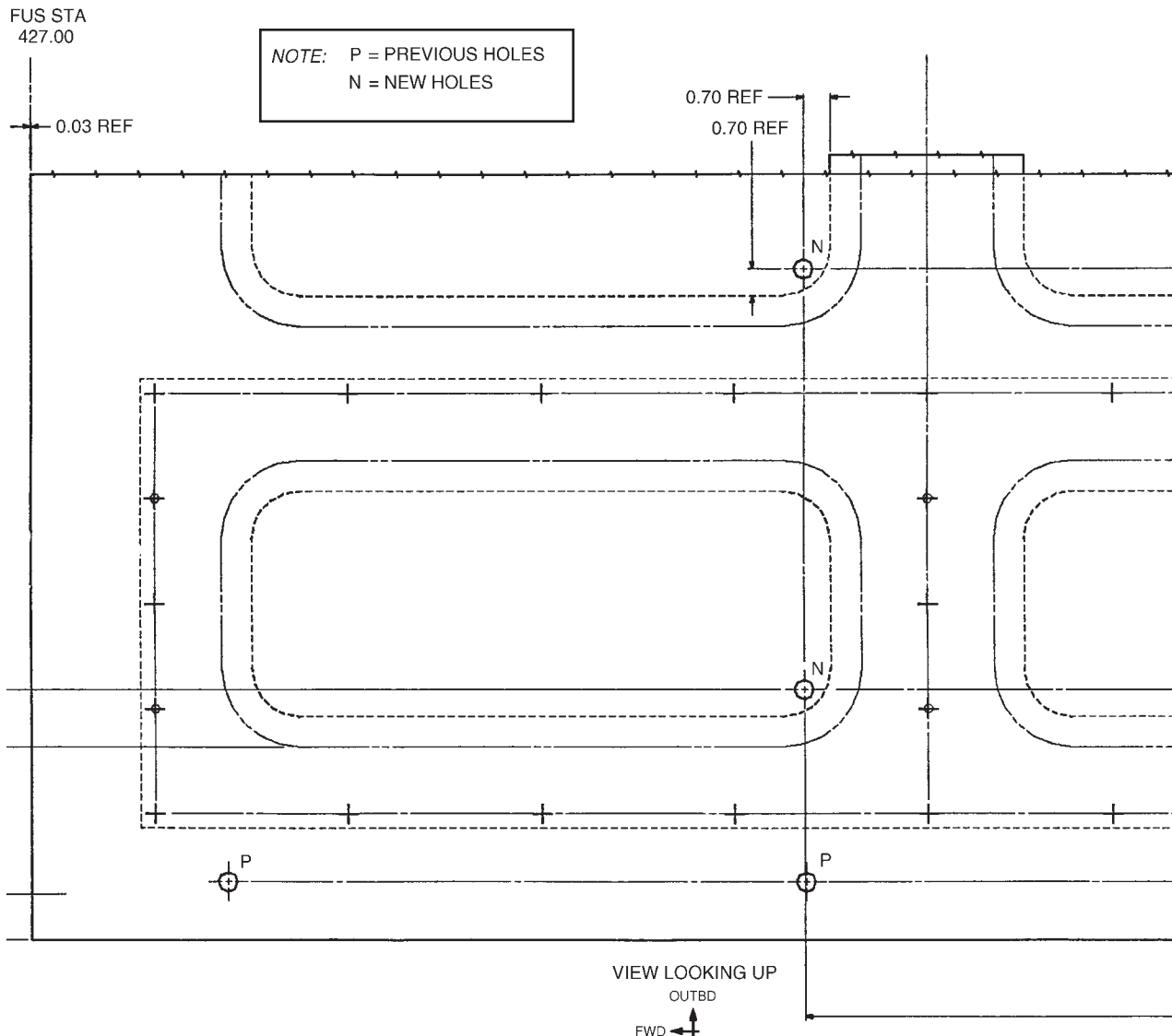

A recent design change in the Left-Hand Main Landing Gear Fairing APU Access Door, Part Number 3311011-17, enhanced the bonding between the inner and outer skins of this component.

One of the purposes of this improvement to the bonding was to help prevent corrosion by keeping water from entering the spaces between the outer skin and the interior stiffener. As a further step to seal this structure, and to ensure that moisture originating in the ambient air was excluded from the panel's interior spaces, the drain holes were deleted from the interior skin.

While this concept was plausible in theory, it has not turned out to be successful in practice. Several instances have been reported in which varying quantities of water have been found entrapped in the redesigned panel.

Condensation appears to be the only way water can gain access to the interior of this panel, but whatever the source, it is a relatively simple matter to keep any moisture that does happen to penetrate into these spaces from accumulating and possibly causing problems. Lockheed Martin Engineering recommends that the 5 previous drain holes be put back in, and an additional 4 be added in accordance with drawing 3311011, revision J, shown in reduced scale below. The locations of the 5 previous drains are marked with **P** symbols, the 4 new holes with **N** symbols.

This will change the access panel to the preferred configuration and prevent the accumulation of water within the panel. Be sure to treat all affected areas in accordance with the appropriate corrosion protection measures listed in the approved structural repair manual for your aircraft. □

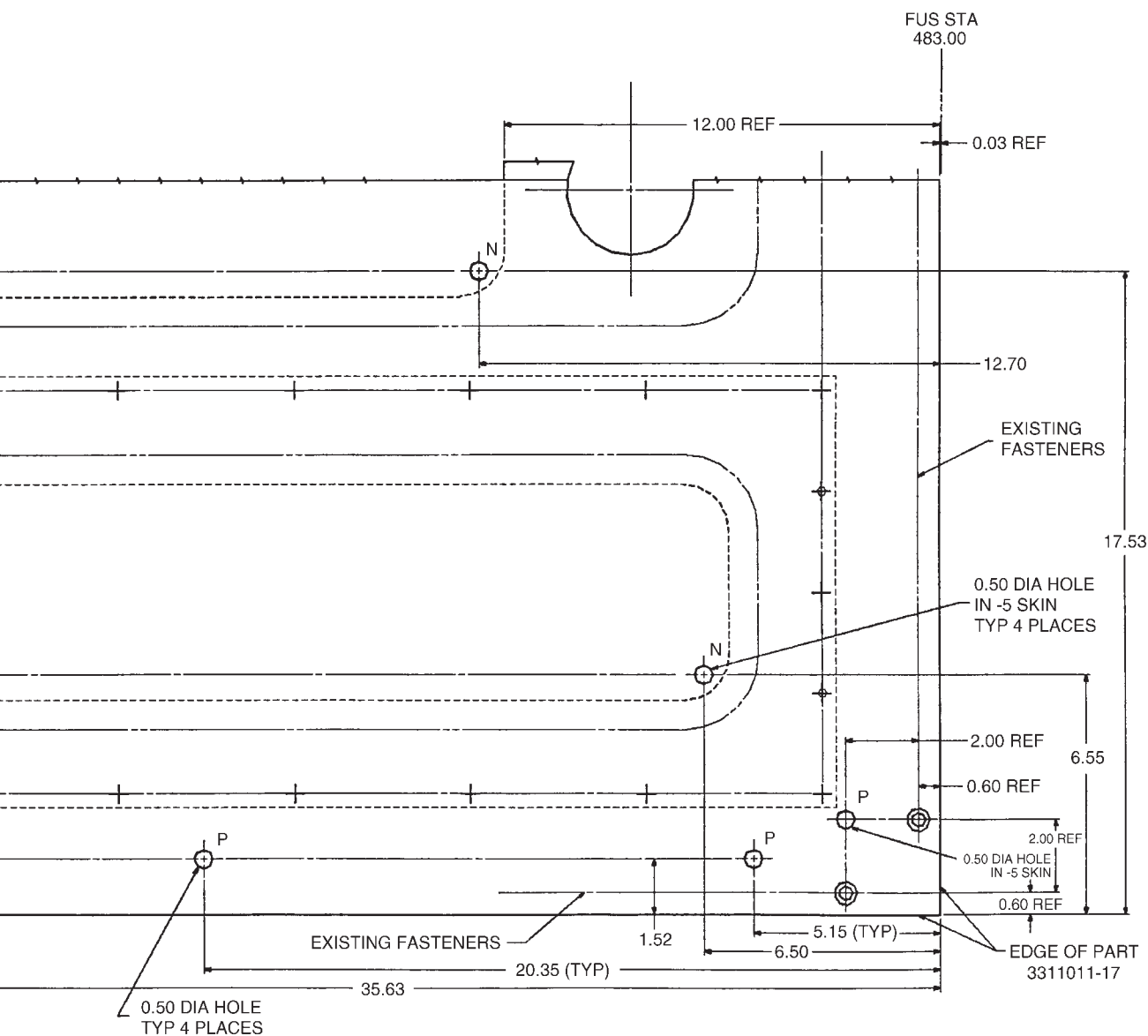

# On Board



by **Julius Alexander**  
*Public Relations Representative, Senior  
Lockheed Martin Aeronautical Systems*

## the C-130J

Typically, a turboprop transport cruises at altitude ranges from 17,000 to 25,000 feet. The C-130H, depending on load, temperature, and mission, can comfortably cruise in the mid twenty-thousands by stair-stepping, periodically climbing and leveling out at intermediate altitudes as the fuel load is burned off.

The C-130J, however, can climb directly from takeoff to 29,000 feet, and on to 35,000 feet, right along with the pure jets. The airplane has even been flown to an altitude of 42,000 feet during testing. This means that C-130J is capable of taking advantage of the lower fuel consumption, greater payload, and longer range offered by flight at these higher altitudes. It all adds up to significantly lower operating costs, and pays big dividends in operational capability.

This improved performance of the new C-130J was predicted by program engineers, and is now being verified in an extensive test program by a team of more than 300 personnel that includes engineers, test pilots, mechanics, and technicians. The team is working to gather essential data that will provide the basis for the aircraft operational flight manual and verify that all design objectives are met.

### **Digital Propulsive Power**

The C-130J's state-of-the-art, digitally controlled propulsion system consists of four AE 2100D engines,

each flat-rated at 4591 prop shaft horsepower. They generate 25% more thrust and have 15% greater fuel efficiency than earlier C-130 propulsion systems. The new engines are coupled to advanced, all-composite, six-blade Dowty Aerospace R391 propellers that are lighter in weight and have fewer moving parts than the propeller systems used on previous Hercules airlifters .

The new propulsion system achieves these benefits through improvements in several areas. One is that the core engine on the new Hercules can support the same torque output at higher altitudes and on hotter days without exceeding temperature limits. Another factor is that the new Dowty propeller is more efficient, and therefore able to deliver more thrust for the same torque. It is the combined effect of the new propulsion system gives the C-130J its capability to cruise at 35,000 feet and beyond early in a mission.

### **Flight Station Technology**

The heart of the C-130J's advanced technology is its modern flight station, with four multifunction liquid-crystal displays and two holographic head-up displays. The displays present formats for primary flight information, aircraft system status, crew alerts, navigational awareness, radar, and engine performance monitoring.

All of these displays are Night Vision Imaging System (NVIS) compatible. The NVIS system enables



the crew to operate the C-130J in nearly total darkness with the aid of special night-vision devices, should operational requirements dictate.

Two mission computers and two backup bus interface units provide vital operational redundancy for the J-model. These computers also provide for an integrated diagnostics system to advise the crew of the status of the aircraft's various systems.

### **An Expanding Envelope**

Although in outward appearance the C-130J is very similar to the C-130H and earlier models of the Hercules, its advanced propulsion system, instrumentation, and avionics, all driven by mission computers and sophisticated software, made testing this aircraft every bit as complex as testing a new fighter.

All new or modified C-130J systems are thoroughly flight-tested to ensure that they meet all functional and operational design requirements. Those systems which are part of the civil aircraft configuration are tested for compliance with the appropriate FAA regulations as well. Approval by the FAA is crucial to obtaining a Type Certificate for the commercial version of the Hercules II.

A limited amount of structural testing is being performed on the new airlifter. The incorporation of lighter engines and propellers reduced the weight of the wing

and changed its mass distribution. As a result, testing was required to establish that the C-130J with its lighter wing is free of flutter throughout the entire speed and altitude envelope. This was accomplished through ground vibration and flight flutter testing. The propeller was tested to show that the composite propeller blades operate within design strain limits and that stresses in the prop shaft are not exceeded.

Such a thorough testing program inevitably involves operating the aircraft in regimes that would never be encountered during normal flight. For example, the new C-130J has already reached speeds as high as .67 mach in dives out of 37,000 feet, and has also been flown at speeds as slow as 70 knots per hour in deliberate power-on stalls.

All the tests conducted to date have confirmed the theoretical studies with regard to the improved performance of the airplane in terms of takeoff thrust, inflight performance, and landings using reverse thrust. Continuing C-130J flight evaluations are expected to further confirm the new aircraft's improvement in performance and reliability over earlier models of the Hercules. Among the expected C-130J improvements are 40% greater range, 40% higher cruise ceiling, 50% decrease in time-to-climb, 21% increase in maximum speed, and a 41% decrease in maximum-effort takeoff run. It's a combination that helps make the C-130J the all-purpose airlifter of choice for the 21st century. □





***Lockheed Martin Aeronautical Systems Support Company***

Airlift Field Service Department  
2251 Lake Park Drive  
Smyrna, GA 30080-7605

